

What's in the Box

Overview

Installing the Battery

Using Your Cooler

Powering On/Off

Screen Guide

Using the App

Settings

Powering Your Cooler

AC

Car

USB-C

Solar Panel (100W Max, 12V-30V)

Maintenance Best Practices

FAQ

Specifications

Warranty Policy

What's in the Box

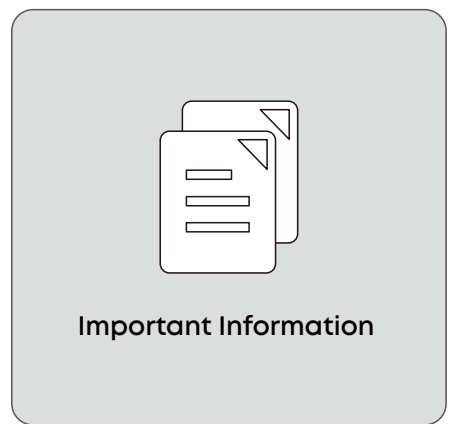
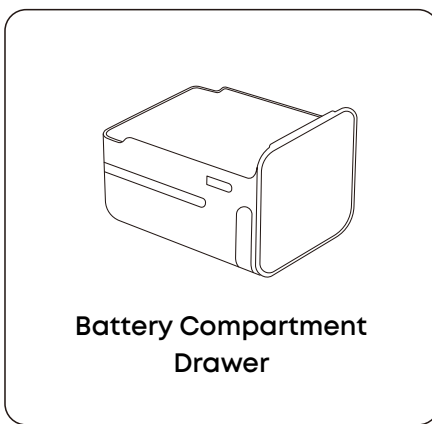
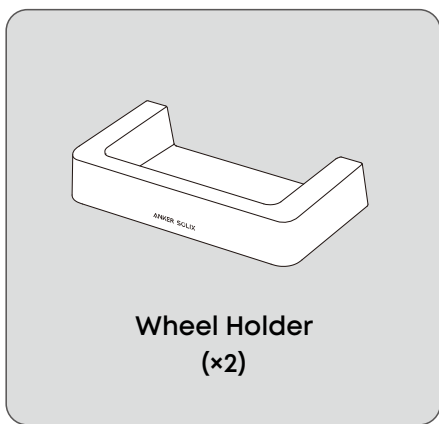
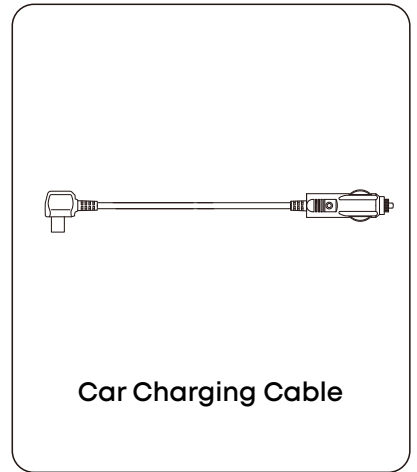
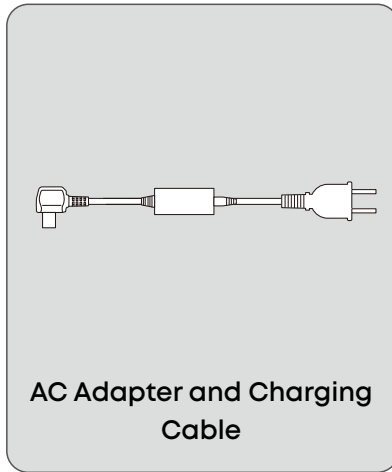
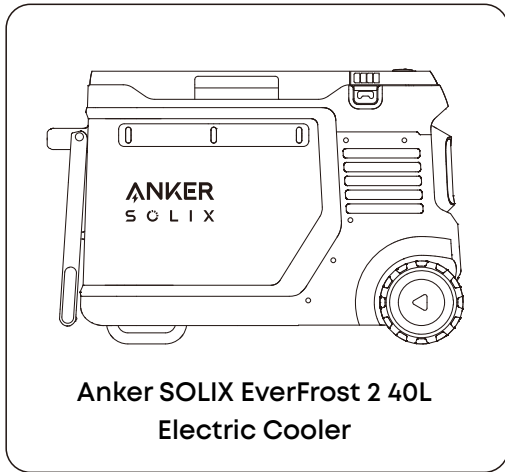

Overview

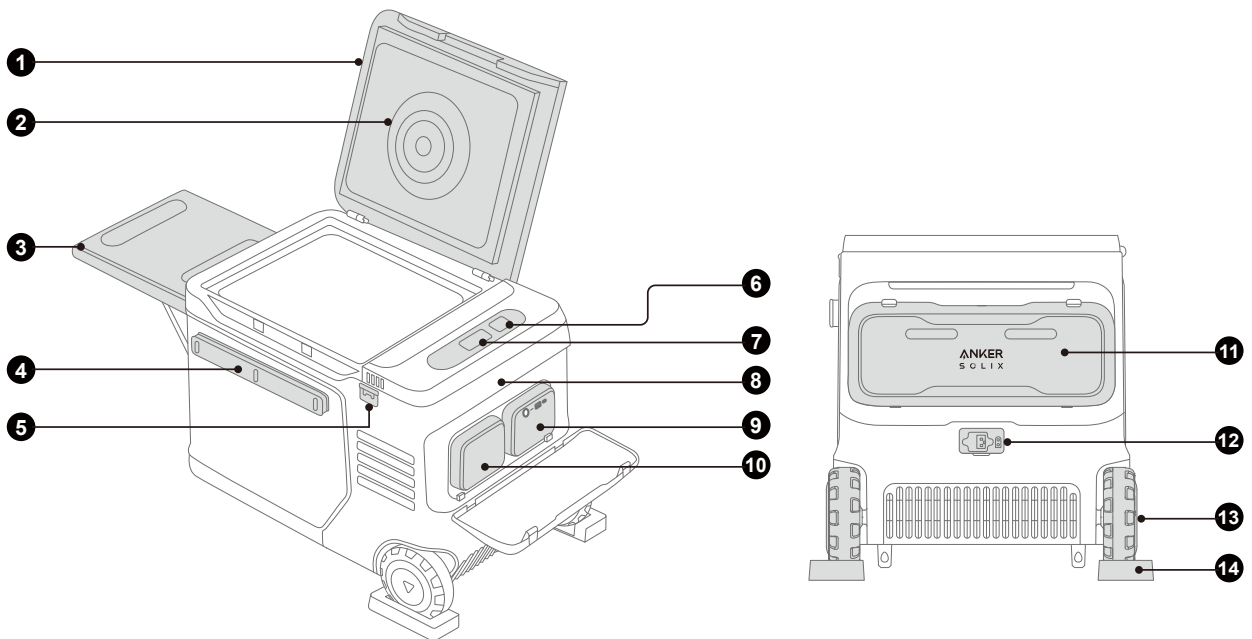

- ❶ Cooler Cover
- ❷ Circulating Fan
- ❸ Tray Table*

Note: Load capacity is 30 kg (66 lb).

- ❹ Bar**

Note: For accessories such as rod and knife racks, tabletops, and cups, align the protruding strip at the back of the accessory with the notch on the bar and insert it fully. Refer to the accessory instructions for details. Accessories can be purchased separately from EverFrost 2.

- ❺ Bottle Opener
- ❻ Interactive Icon
- ❼ Display
- ❽ Handle
- ❾ Main Battery
- ❿ Accessory Container / Secondary Battery
- ⓫ Battery Cover
- ⓬ Input Ports
- ⓭ Wheel
- ⓮ Wheel Holder

*Using the tray table :

1. Lift the tray table.
2. Apply moderate force to release the stand, then secure it into place.

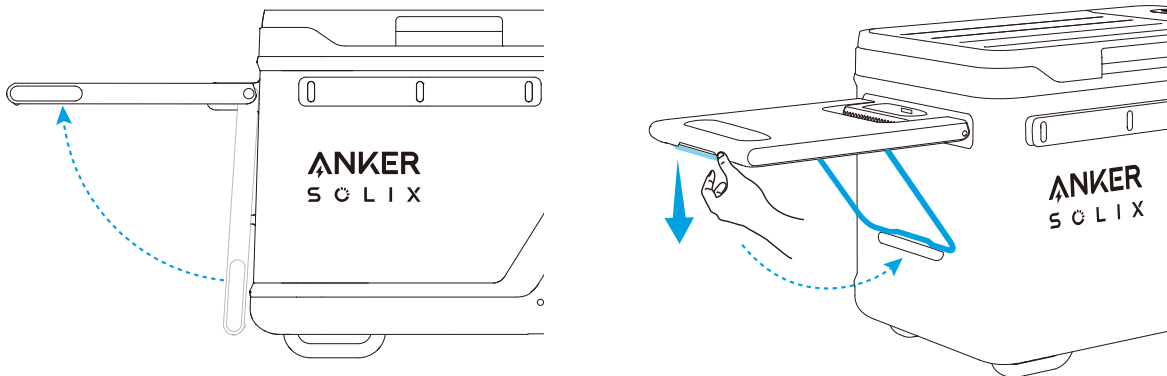

**Using the bar :

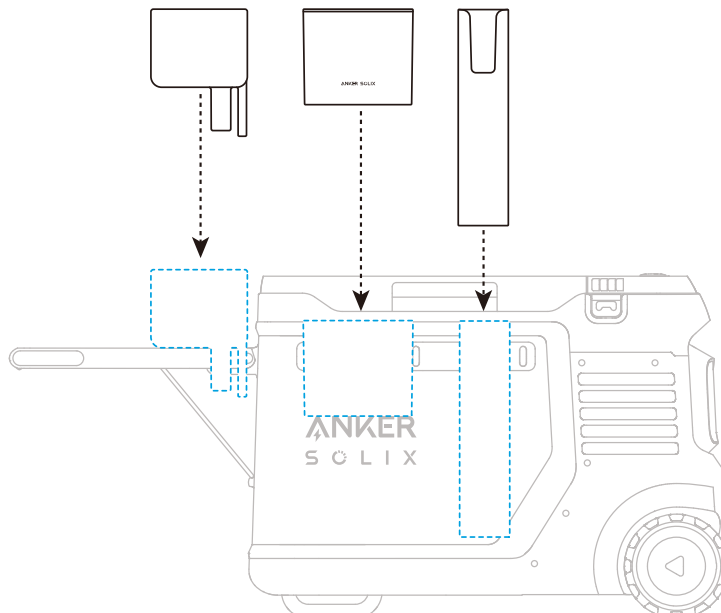

Installing the Battery

- If there is already a battery in the cooler, please skip this step.
- The cooler can be installed with one or two batteries. When using one battery, please install it in the right battery compartment. Do not place any objects in the empty battery compartment to avoid contamination of the internal battery contact pins, which could lead to poor battery contact or a short circuit.

Open the battery cover. Place the battery inside, and you will hear a click when the installation is successful. If the cooler is turned on, the screen will display "Battery Connected." Close the battery cover. To remove the battery, lift its handle.

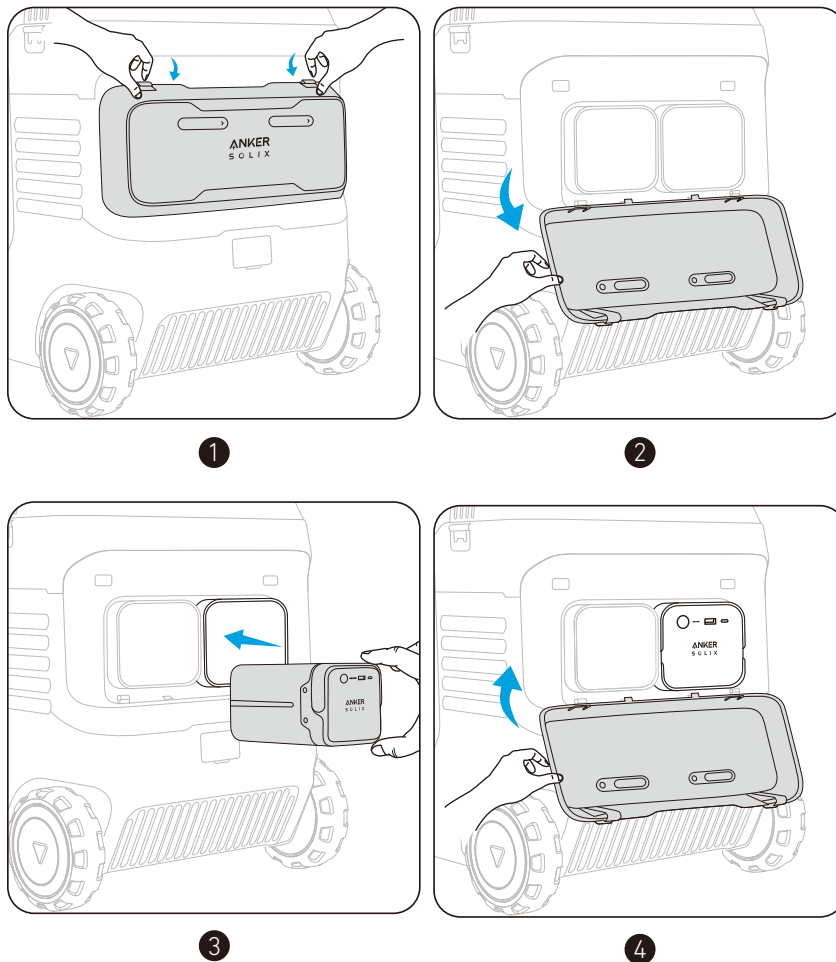

Using Your Cooler

⚠ Important Tips for Using the Circulating Fan

1. Do not put your fingers or other objects into the fan cover.
2. Do not allow children to use this product without adult supervision.
3. When using the air-cooling function, do not cover the fan surface. Covering the fan surface leads to poor motor performance and reduced cooling.
4. Do not disassemble the fan cover. If you need to disassemble the fan cover under special circumstances, make sure the cooler is powered off.

Powering On/Off

- To ensure reliable compressor operation after long transportation, lay the cooler flat for three hours before turning it on for the first time. Ensure the cooler is connected to the mains power with a charger or has a battery inside before turning it on.
- **Before using the cooler for the first time, recharge it to activate.**

Press <⏻> for 3 seconds to turn your cooler on or off.

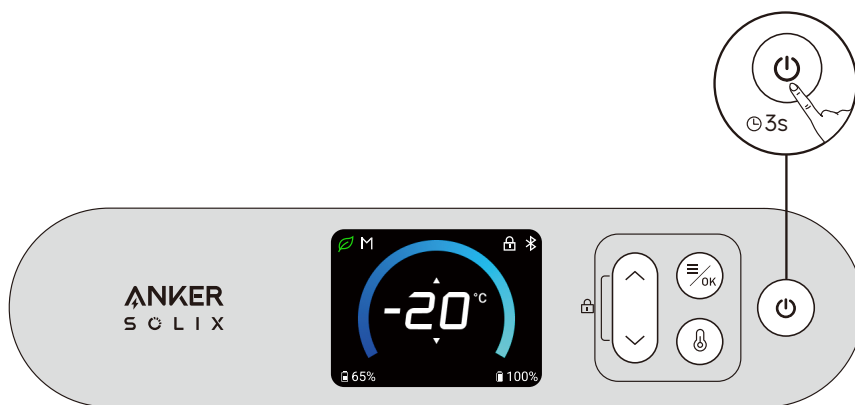

Screen Guide

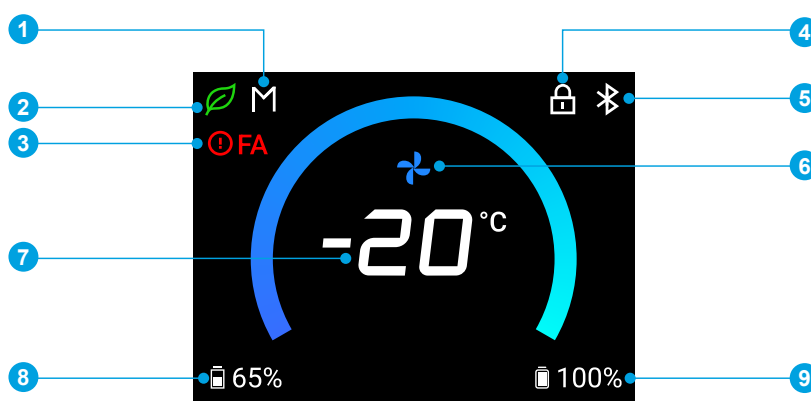

- 1 Protective Voltage (M/H/L)
- 2 Eco/Smart/Max Mode
- 3 Fault Code*
- 4 Child Safety Lock
Press <🔒> once to turn the child safety lock on/off.
- 5 Wi-Fi / Bluetooth
- 6 Max Mode
This icon only appears when the cooler is in Max mode.
- 7 Temperature
- 8 Battery Level of Secondary Battery
- 9 Battery Level of Main Battery

*Fault codes and fault types:

Code	Fault Type
F1	Motor MOS Short-Circuit
F2	Motor Input Overvoltage
F3	Motor Input Undervoltage
F4	Motor Overheating
F5	Motor Blocked / Motor Startup Failure
F6	Motor Software Overcurrent
F7	Motor Fan Overcurrent

F8	Motor Overspeed
F9	Motor Blocked at Startup
FA	Motor Phase Loss
FB	Motor Voltage Drop
FC	Communication Error Detected by MCU
FD	Cooler Tilt Angle Greater Than 30°

Using the App

Connecting the Cooler

1. Connect with Wi-Fi and download the app to remotely control your cooler.

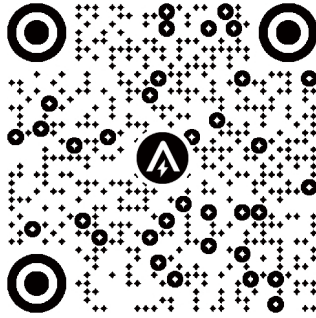

2. Once the cooler is powered on, its Bluetooth will automatically activate. Next, turn on Bluetooth on your phone and add the cooler in the app.

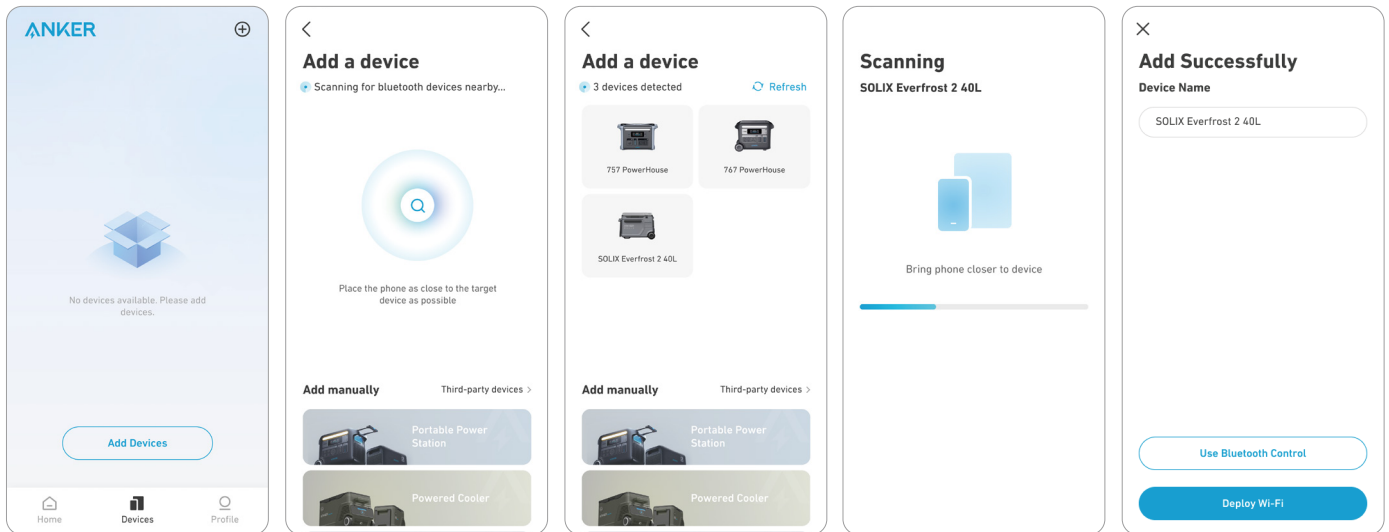

3. When added successfully, on the screen will turn steady white.

* If you want to turn on /off Bluetooth, press for 2 seconds.

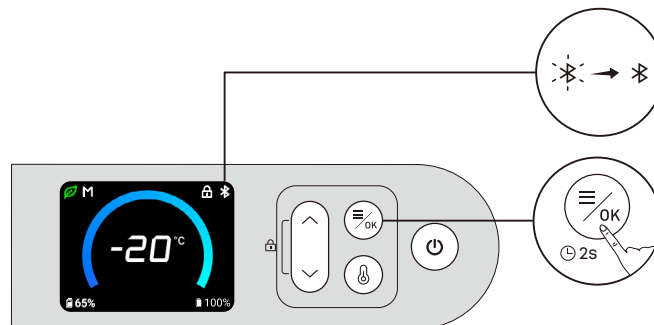

4. We recommend that you connect to Wi-Fi to use the cooler for a better experience. After connecting to Wi-Fi successfully, the icon on the screen will change from to .

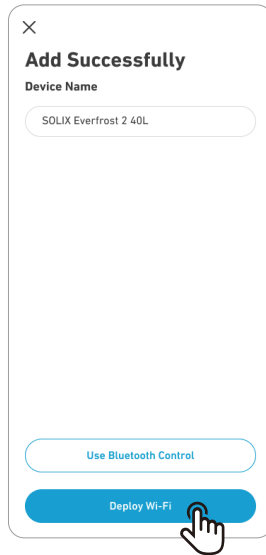



Installing Firmware Updates

You will receive a notification before updates are installed. Your cooler must be charging and connected to Wi-Fi or Bluetooth to complete the update. If there is a battery in the cooler, the battery level needs to be above 1%.

Settings



You can set the temperature and mode in the app or as follows.

Setting the Temperature

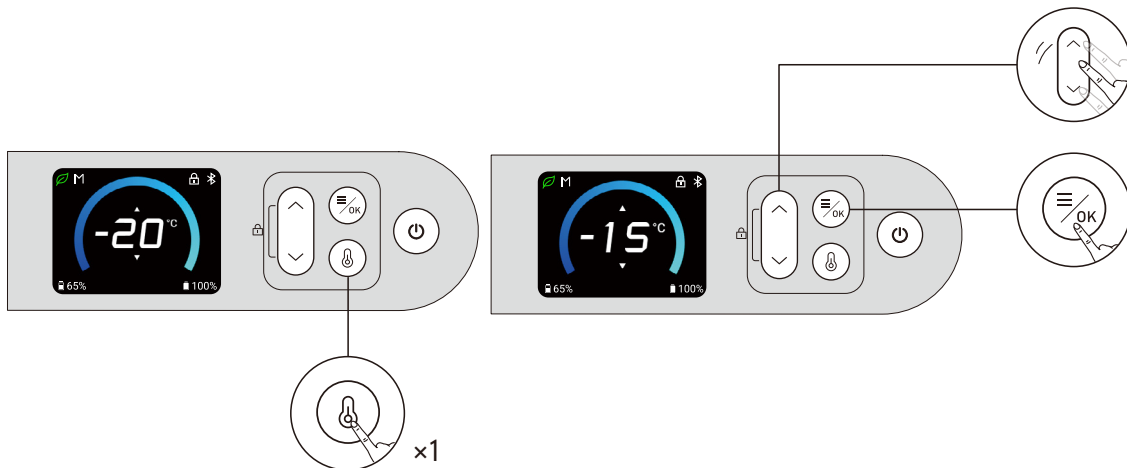
Press  once to enter the temperature settings. Then use  to adjust the temperature. Confirm the temperature and return to the homepage by pressing .



Setting the Mode

Press  to enter the Settings page, press  to navigate and select Mode. Choose between Eco, Smart, or Max modes and press  to confirm.

- **Eco Mode:** Eco mode is the quietest mode and saves the most energy for the longest battery life. It stops the air-cooling fan to conserve power, but cooling speed may not be as fast as other modes.
- **Smart Mode:** Smart mode, also the default mode of the cooler, utilizes integrated Negative Temperature Coefficient (NTC) sensors to detect both internal and external temperatures. This enables the system to decide how the compressor and fan should function, achieving an optimal balance between cooling performance and energy efficiency.
- **Max Mode:** When Max mode is activated, the cooling fan circulates cool air, and the system uses maximum power for cooling. Activating Max mode will reduce battery life, so only use this mode as needed.

 To ensure safety during use, the cooling fan will automatically pause when you open the cooler cover.

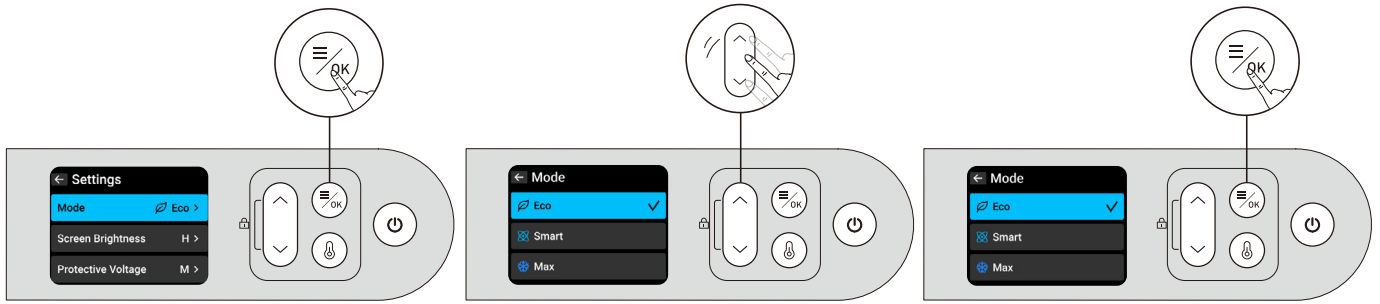

Powering Your Cooler

We do not recommend using multiple charging methods at the same time.

AC

Power the cooler by connecting to a wall outlet with the AC charging cable.

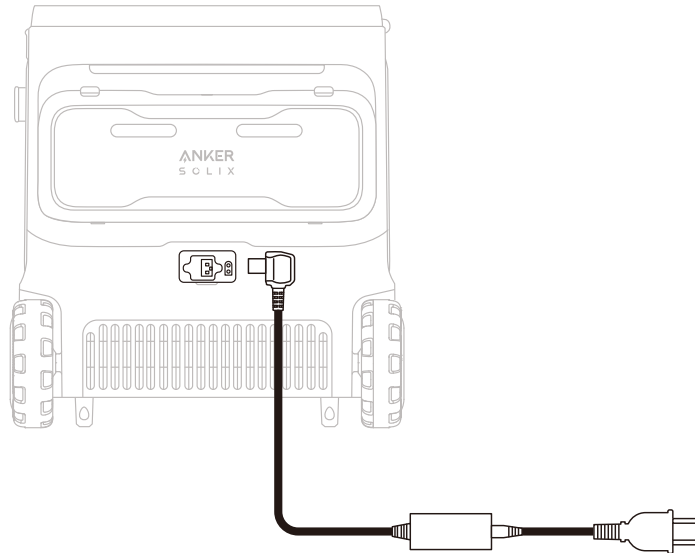



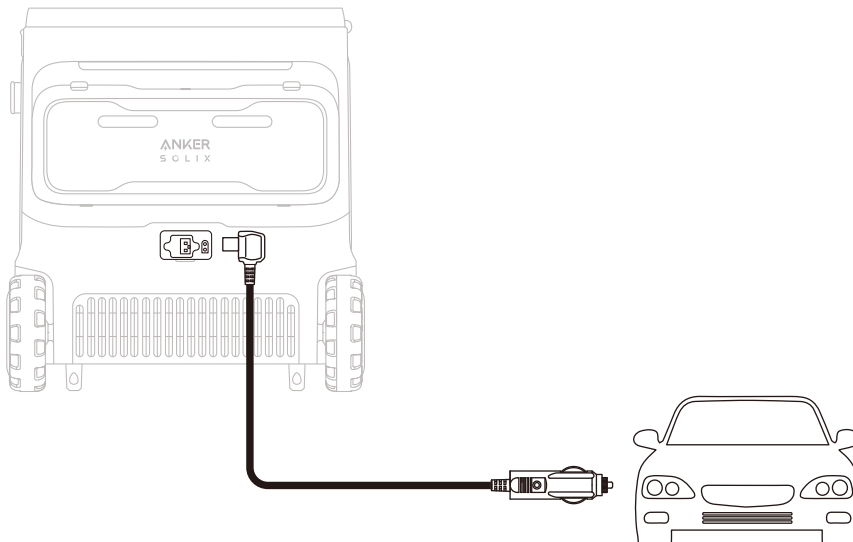

Car

Connect the cooler to a car's output port with the car charging cable.



*Car Battery Protection Grades

The cooler supports three levels of battery protection. To modify the level of battery protection, press <  > first, and then press <  > to choose Protective Voltage, and confirm it by pressing <  >. Continue pressing <  > to choose between "L/M/H", and confirm the level with <  >. When the cooler is connected to a car battery (lead-acid battery), the cooler's battery protection prevents the car battery from over-discharging.

If your cooler does not have a battery and the car's battery voltage is lower than your cooler's set value in that scenario, your cooler will stop working.

If the car's battery voltage reaches the recovery value needed for battery protection, the cooler will return to the power-on/off state it was in before the protection was activated.

If the cooler has a battery and the car battery's voltage is lower than the set value for that scenario, the cooler switches to its own battery power and does not shut down automatically.

Note: When powering the cooler via a car, please disable the battery protection function to avoid accidental triggering.

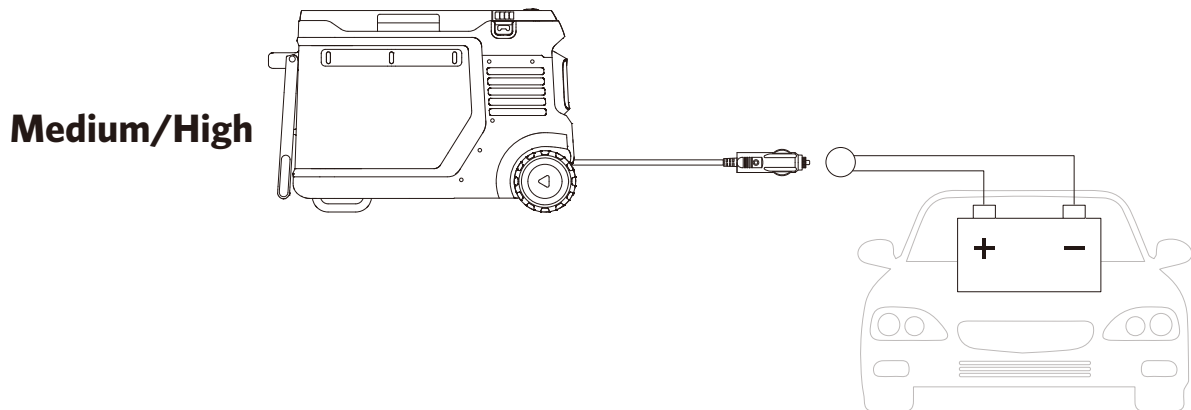
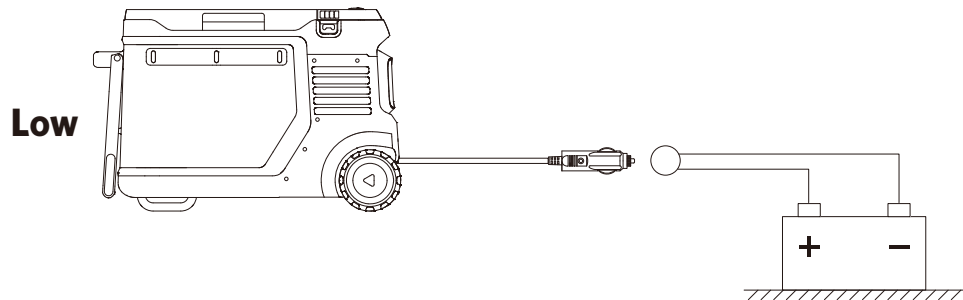

USB-C

Note: The USB-C cable and charger are not included in the package.

Power the cooler by connecting the battery to a wall outlet with the USB-C cable.

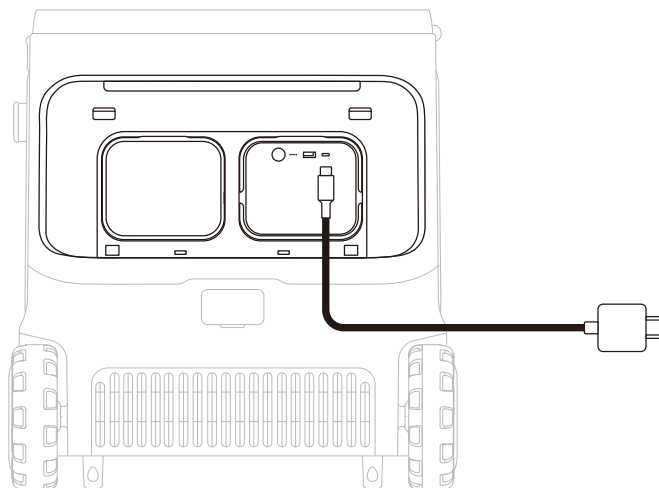

Solar Panel (100W Max, 12V-30V)



- This method of powering can only be used when the battery is in the cooler.
- To protect the compressor's lifespan, the cooler will only be powered when the battery level is at least 5% during solar charging input.

Power the cooler by connecting the battery to a solar panel with an XT60 cable.

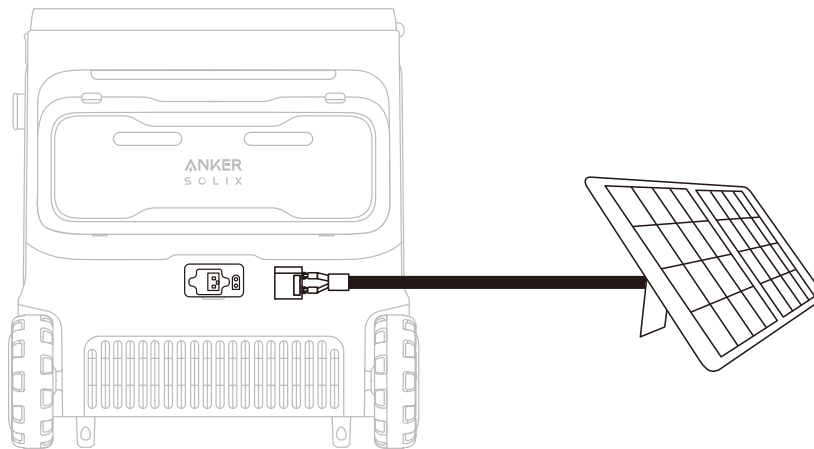

Maintenance Best Practices

- Turn off all power before cleaning to ensure safety.
- Clean after disassembly and then install in reverse order. Do not use excessive force during disassembly to avoid damaging the components.
- Use a soft cloth with a neutral detergent for wiping. Do not use scouring powder, benzene, hydrochloric acid, hot water, coarse brushes, abrasives, or hard objects to clean the cooler, as they may damage or corrode it.
- Regularly clean the interior and exterior of the cooler with a damp cloth.
- Never use running water to wash the interior and exterior of the cooler or immerse it in water.
- To ensure that the cooler is able to ventilate and dissipate heat, the air inlet and outlet must be free of dust and dirt.
- After cleaning the cooler, check the power cord for any damage or moisture, and ensure that the plug is not overheated. Make sure everything is in order before connecting the power supply.
- Before connecting the power, dry the cleaned cooler with a soft dry cloth or sponge. This will prevent water or other liquids from remaining in the electrical components, which may cause electric shock or short circuit hazards.
- We recommend placing the cooler on a level surface for use. When the tilt angle exceeds 30°, it will affect the normal operation of the compressor.

FAQ

1. What type of battery does the cooler use?

LFP (Lithium Iron Phosphate) battery.

2. Can the cooler be connected to the solar panel without the battery?

No. The cooler must have a battery inside when a solar panel is connected. Otherwise, the cooler will not work.

3. Is there anything to be aware of when using the cooler for the first time?

We recommend laying the cooler flat for three hours before turning it on for the first time.

4. When there is a battery in the cooler, does the external power supply give priority to charging the battery or supplying power to the cooler?

The external power supply will prioritize charging the cooler.

5. Can the cooler be transported for long periods?

Yes. Make sure to lay the cooler flat for three hours before turning it on after a long transportation.

6. What's the maximum load capacity of the bar?

It's 30 kg / 66.1 lb.

7. Is it normal to have a smell when I first use the cooler?

Yes. During production, foaming agents are used for better thermal insulation. These agents leave a slight residual smell, but it's harmless. Before using it for the first time, place the cooler in a well-ventilated area with the cover open.

Specifications

Cell Capacity	288Wh
Capacity	40 L / 42 qt
Size	749 × 459 × 493 mm / 29.5 × 18.1 × 19.4"
Battery Compartments	2
Temperature Range	-20°C to 20°C / -4°F to 68°F
AC Input Power (Charging)	95W Max
Solar Panel Input	12-30V = 8.2A (100W Max)
USB-C1 Input	5V = 3A / 9V = 3A / 15V = 3A / 20V = 3A (60W Max)
USB-A Output	5V = 2.4A (12W)
USB-C1 Output	5V = 3A / 9V = 3A / 15V = 3A / 20V = 3A (60W Max)
USB-A and USB-C1 Total Output	72W
Discharging Temperature	-20°C to 40°C / -4°F to 104°F
Charging Temperature	0°C to 40°C / 32°F to 104°F
Waterproof	IPX3
Net Weight	25 kg / 55 lb

Warranty Policy



3-Year Limited Warranty

Scan the QR code for detailed warranty information.

