

**CHIKOUSA**

CK- | STEEL SOLAR CARPORT | GAZEBO

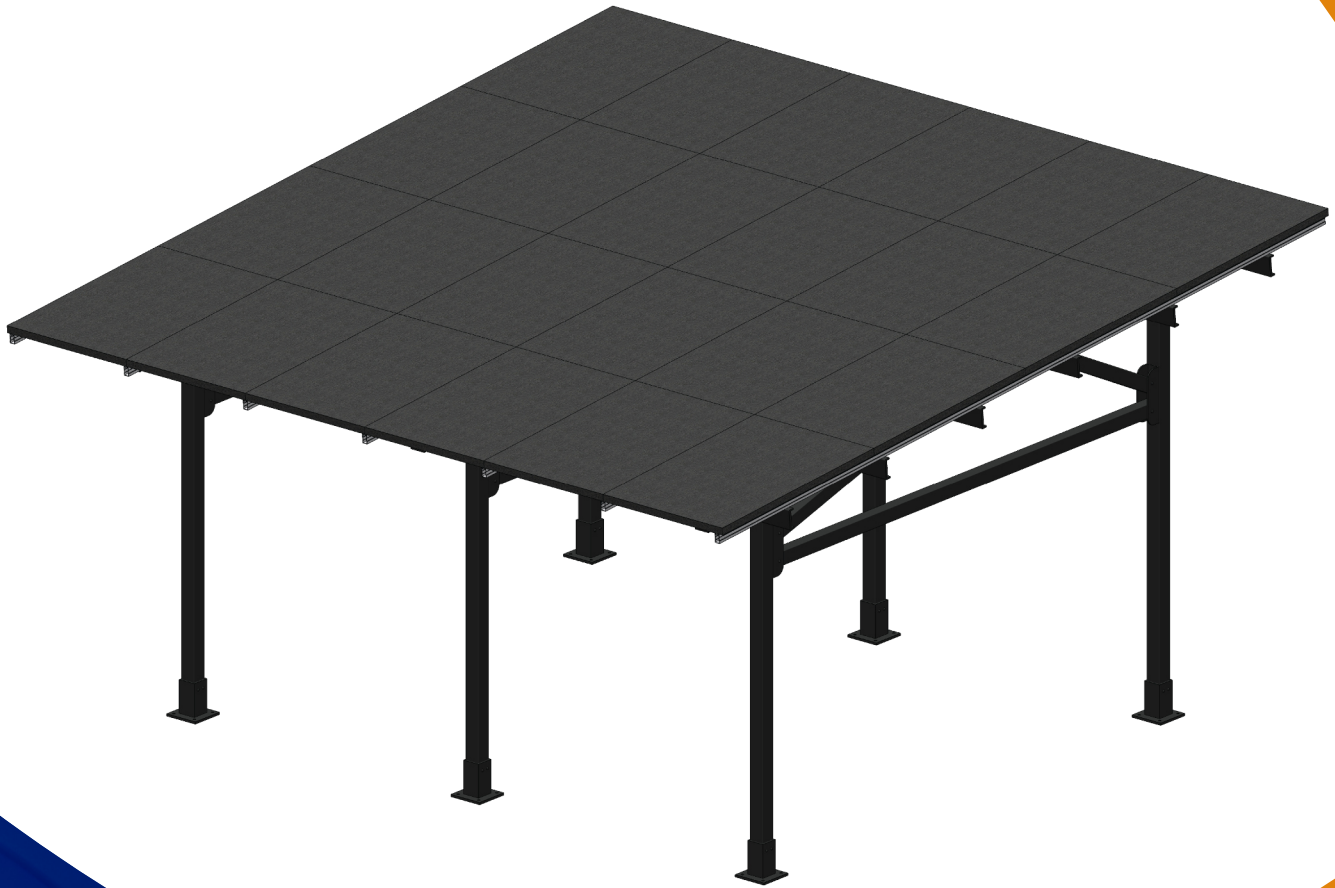

**MAXIMO-185 (2-CAR)  
STEEL SOLAR CARPORT | GAZEBO  
INSTALLATION MANUAL**

VERSION: 02.05.25 | ENG

Always use the most recent version of the installation manual before installing your Carport/Gazebo. The installation Manual is subject to change without notice. Please consult with CHIKOUSA to ensure you are utilizing the latest Install Manual.

## BRIEF DESCRIPTION

The CHIKOUSA Steel Carport/Gazebo is a robust solar carport that can accommodate a wide range of panel sizes, with a max (North/South or Up/Down) span of 270". This structure can be installed with a 2-3 person crew, without the need of any heavy duty tools. The Installation should always be completed by trained professional and/or qualified individuals, who have been adequately instructed and trained about the tasks involved with the installation, including the usage of protective devices, protective measures, relevant provisions, safety regulations and local operating site conditions and have proven competence in all areas of the installation.

Please read carefully this installation manual and all other applicable documents before starting your installation. Please contact CHIKOUSA with any questions that you may have.

## MAINTENANCE

1. When signs of rust appear, or when the paint is peeled or removed, you must take steps to remove the rust and paint the affected areas.
2. You must check the bolts once a year ensuring all connections are secure, and after any major storm or weather occurrence. Tighten all bolts according to torque specs.
3. If the columns of the structure are hit, you must replace the columns of the structure immediately.

## WARNING

If any structural component of the system to include the column, beam, base plate, or rail are damaged they must be replaced immediately.

## FOOTER WARNING

Anyone who plans to dig should call 811 or visit their state's 811 center's website a few business days before digging to request that the approximate location of buried utilities be marked with paint or flags so that you don't unintentionally dig into an underground utility line.

## MEASUREMENT NOTE

Some measurements have been converted from MM to Inches. The accuracy of measurement can vary slightly from mm to inches. Some measurements are available in MM for detailed accuracy. The most critical measurement required is the Base Plate placement location. Please review the Construction Drawings for the Base Plate and Base Plate locations prior to installation.



## REQUIRED INSTALLATION TOOLS

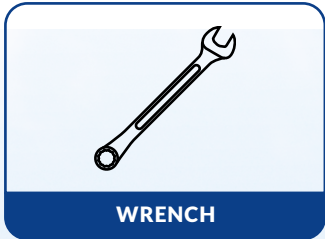
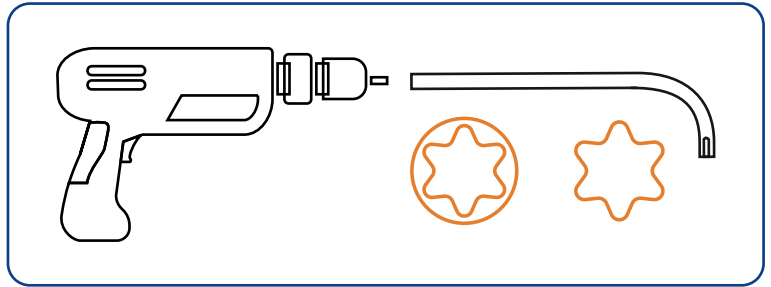
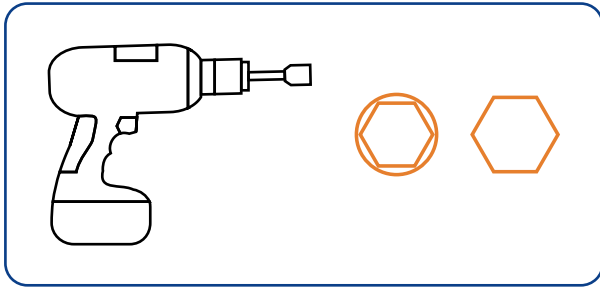

WRENCH



GLOVES

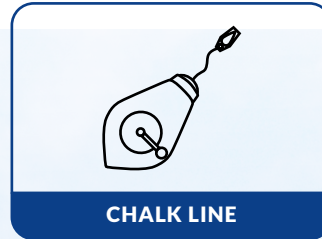

CHALK LINE

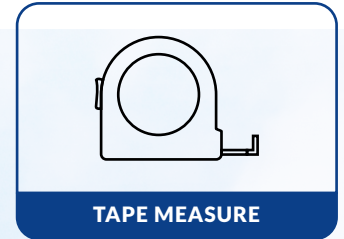

TAPE MEASURE



RUBBER MALLET



HARDHAT



SAFETY GLASSES

## MAIN COMPONENTS



137<sup>3</sup>/<sub>4</sub>"

U RAIL

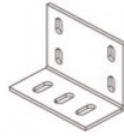

C-CHANNEL FIX KIT

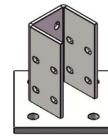

BASE PLATE



7<sup>7</sup>/<sub>8</sub>"

U-RAIL SPLICE

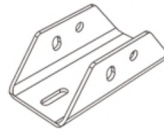

10<sup>3</sup>/<sub>16</sub>"

TOP COLUMN ADAPTER

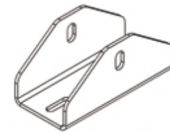

10<sup>3</sup>/<sub>16</sub>"

DIAGONAL BRACE ADAPTER

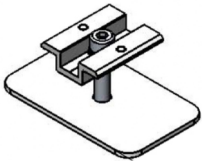

MID-CLAMP

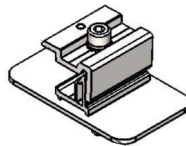

END-CLAMP



RUBBER PANEL GASKET



RUBBER STRIPPING

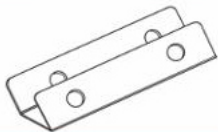

16<sup>1</sup>/<sub>2</sub>"

LOW BEAM/DIAGONAL BRACE ADAPTER

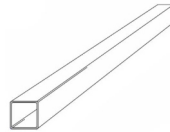

111"

FRONT COLUMN

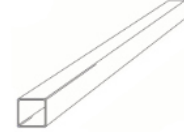

126<sup>1</sup>/<sub>2</sub>"

REAR COLUMN



224<sup>7</sup>/<sub>16</sub>"

L-ANGLE SUPPORT



228<sup>5</sup>/<sub>16</sub>"

TOP SUPPORT BEAM

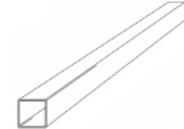

168 1/16"

LOWER HORIZONTAL BEAM

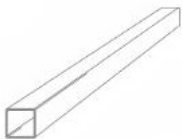

47<sup>1</sup>/<sub>4</sub>"

DIAGONAL BRACE

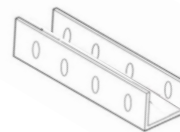

11<sup>13</sup>/<sub>16</sub>"

C-CHANNEL SPLICE



220 1/2", 63"

C-CHANNEL

### NOTE

Customer needs to source materials for footings based on structural engineer specifications.



## MAIN COMPONENTS

### Overview

The following is a diagram that lists the main components of the CK- Carport System.

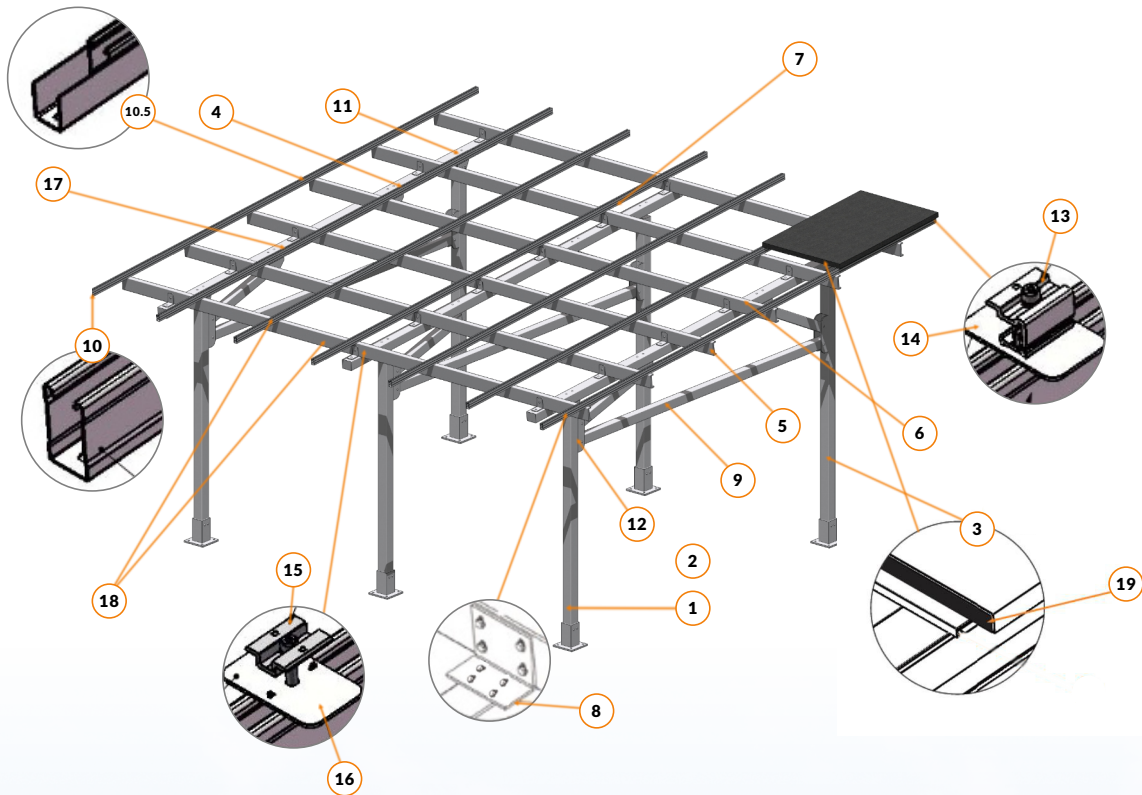

No	Description	QTY
1	Base Plate	6
2	Front Column 111"	3
3	Rear Column 126 1/2"	3
4	Top Support Beam 228 5/16"	3
5	Lower Horizontal Beam 168 1/16"	3
6	Diagonal Brace 47 1/4"	6
7	L-Angle Support 224 7/16"	2
8	C Channel Fix Kit	18
9	C-Channel 220 1/2"	6
	C-Channel 63"	
10	U-Rail 137 3/4"	14

No	Description	QTY
10.5	U-Rail Splice	7
11	Top Column Adapter 10 3/16"	6
12	Low Beam & Diagonal Brace Adapter 16 1/2"	6
13	End Clamp	24
14	End Clamp Share Plate	24
15	Mid Clamp	60
16	Mid Clamp Share Plate	60
17	Diagonal Brace Adapter 10 3/16"	6
18	C-Channel Splice	6
19	Rubber Strip	
20	Rubber Gasket	

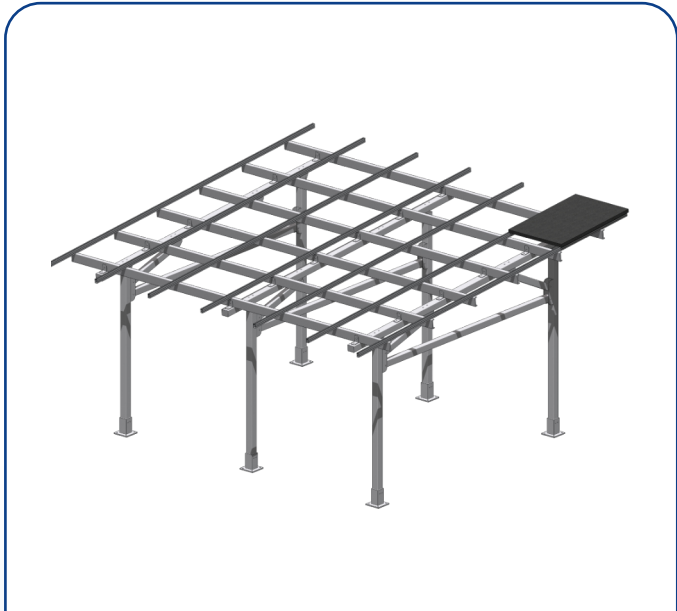

**FRONT VIEW**



**SIDE VIEW**

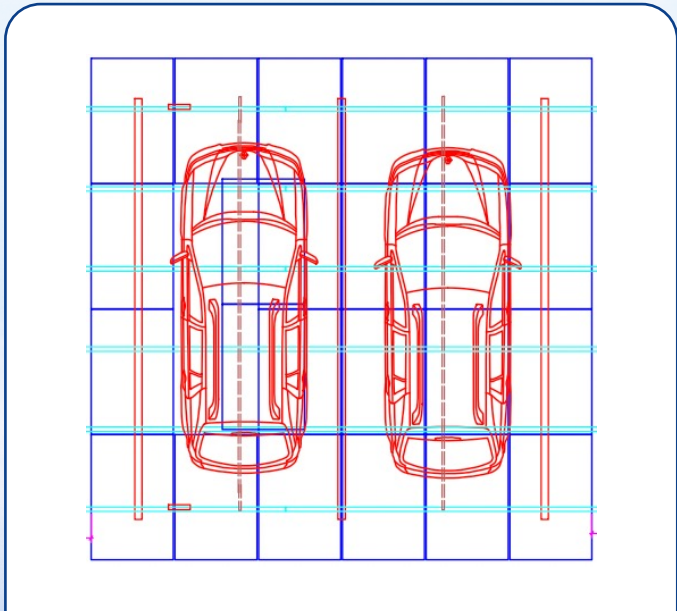







**OVERHEAD VIEW**

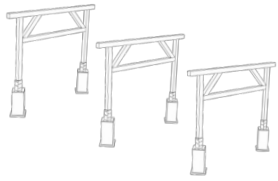

**18 OR 24 SOLAR PANELS**

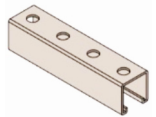

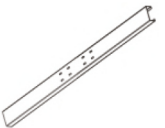
## COMPONENTS LIST

CAT	Picture	Description Part	Details	QTY
1		Carport Support Structure	Front Columns	3
			Rear Columns	3
		CK-ZEM-CP3-5	Base Plate	6
			Top Support Beam	3
		<u>COLUMNS</u> CK-001-016-014	Top Column Adapter	6
			Lower Horizontal Beam	3
		<u>BEAMS</u> GT-001-016-014	Diagonal Brace	6
			Low Beam & Diagonal Brace Adapter	6
		Base 'Plate' CK-GT-001-016-805	HDG Bolt M10*35	168
			HDG Bolt M16*180	158
		GT-001-016-805	HDG Nut M10	168
			HDG Nut M16	156
		Column/Beam Adapters	HDG Washer M10	168
			HDG Washer M16	156
		Beam CK-GT-001-016-014	HDG Spring Washer M10	336
	HDG Spring Washer M16	312		
Column CK-001-016-014				
2		U Rail CK-ZEM-U72-2.5-3500	U Rail 137 3/4"	14
			M-10 30 Nut & Bolt Set	42
3		U Rail Splice CK-009-1062	U Rail Splice	7
4		Rubber Strip CK-IP-160-1133	Rubber Strip	
5		'C' Channel CK-PL-C140-001-016-6000	C-Channel 220 1/2"	6
			C-Channel 63"	6
6		Rubber Gasket CK-WG-083-7250	Rubber Gasket	2

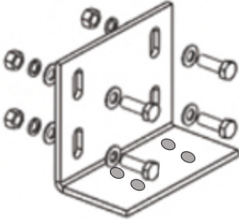
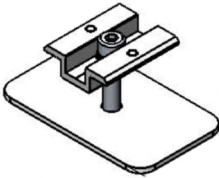
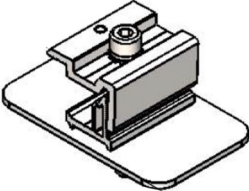
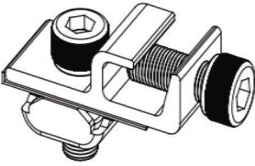
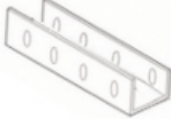
CAT	Picture	Description Part	Details	QTY
7		L Angle Support	224 3/8"	2
8		C Channel Fix Kit CK-PL-GT001-016-14	C Channel Fix Kit	18
			HDG Bolt M10*35	72
			HDG Bolt M16*140	36
			HDG Nut M10	72
			HDG Nut M16	36
			HDG Washer M10	144
			HDG Washer M16	72
			HDG Spring Washer M10	72
			HDG Spring Washer M16	36
9		Mid Clamp Mid Clamp Share Plate	Mid Clamp	60
			Mid Clamp Share Plate	60
			Self Tapping Screw	60
			SS304 Bolt M8*45	60
			SS304 Spring Washer M8	60
10		End Clamp End Clamp Share Plate	End Clamp	24
			End Clamp Share Plate	24
			Self Tapping Screw	24
			SS304 Bolt M8*45	24
			SS304 Spring Washer M8	24
11		Grounding Lug CK-GTC-R2	Grounding lug - weeb lug 8.0	6
			SS304 outer hex bolt 1/4" *0.6"	6
			SS304 inner hex bolt M8*20	6
			SS304 inner hex bolt M8*20	6
12		C Channel Splice	M10*35 Bolts	96
			M10 Flat Washer	96
			M10 Spring Washer	96
			M10 Hexagon Nut	96



## INSTALLATION STEPS

### 1. Build Base

#### Solution A, Build base

- ✓ Mark footer location according to the diagram. Verify all angles are square (See Attached Planset).
- ✓ Dig footers and make base with anchor bolts according to site conditions and system specifications and based on your structural engineer instructions for foundations requirements.
- ✓ If the ground is unlevel, ensure that all footer placements are level and at the same height regardless of the terrain elevation. Never install the structure tilted, the columns must always be straight.
- ✓ The structure's foundations should be calculated taking into account site conditions, soil type, seismic conditions, maximum wind and snow loads for the site location and the product mechanical loading specifications. In some cases, a geotechnical study is required. Please consult with your local structural engineer.
- ✓ In areas subject to freezing, footer depths may have to increase to resist freeze heave. Always consult a structural engineer to confirm footer depth and dimension.

#### Solution B, Concrete anchors

- ✓ Concrete anchors can be utilized if approved by a structural engineer.

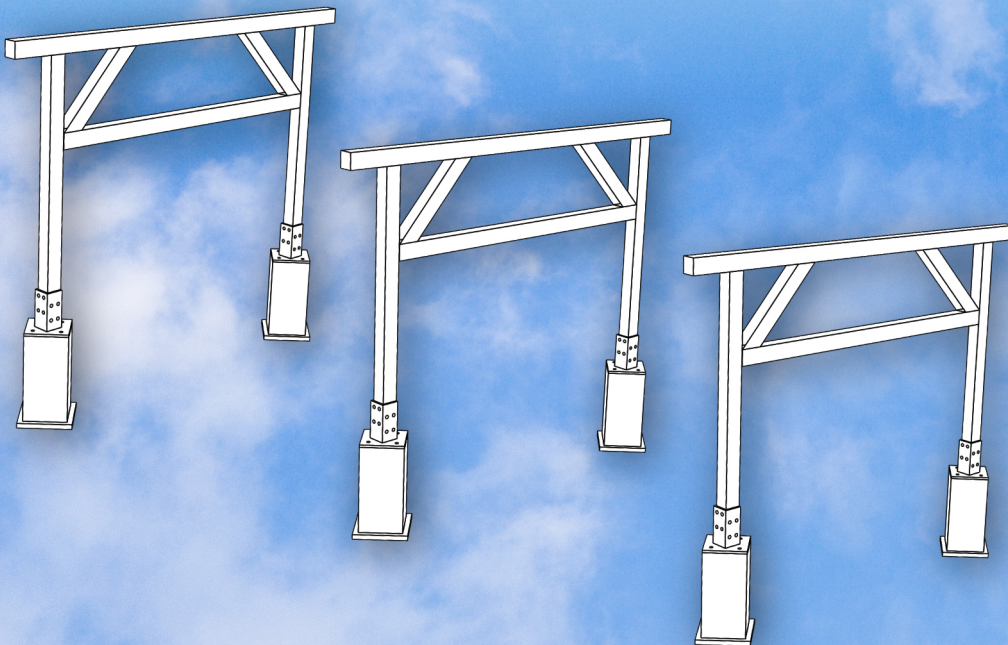

## 2. Install Base Plates

- ✓ Slide the column base plate over the concrete anchors and secure them. If you are using leveling nuts to level the column base plate. Correct any shifting if needed and repeat for the other three column base plates. Fill the gap between the base plate and the footing with Dry-pack non-shrink grout.
- ✓ Verify the distance between the front and rear column conform with the attached planset.

Products Name	Quantity
Base	6

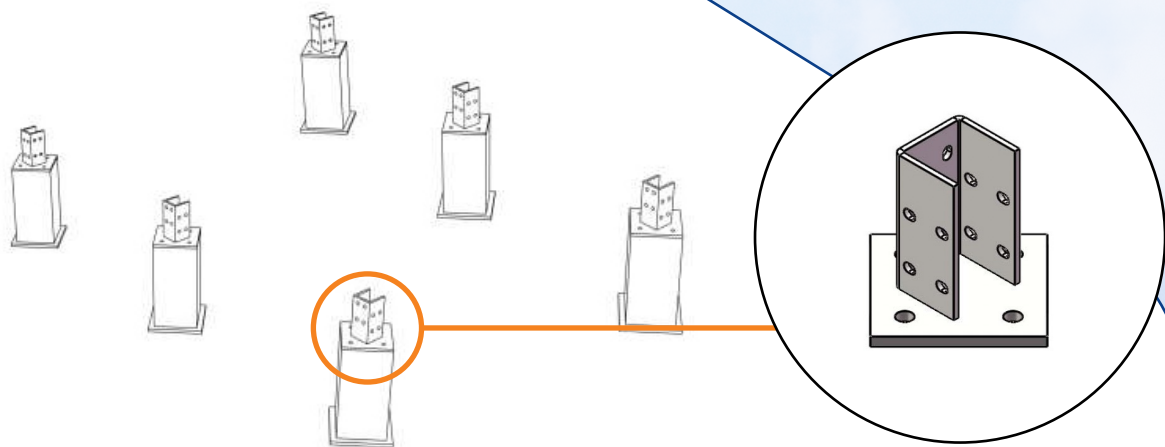



## 3. Fix Adapter

- ✓ A . Fix Low Beam/Diagonal Brace Adapter to Front & Rear Columns
- ✓ B1. Attach C-Channel Fix Kit to Support Beam
- ✓ B2. Attach Top Column Adapter to Support Beam

Front Column: 111"  
 Rear Column: 126 1/2"  
 Low Beam/Diagonal Brace Adapter: 16 1/2"  
 Top Column Adapter: 10 3/16"  
 Support Beams: 228 5/16"

Products Name	Quantity
Top Column Adapter	6
M16*140mm Bolt Kits (1 big flat washer + 1spring washer + 1 nut)	36
Lower Horizontal Beam/Diagonal Brace Adapter	6
C-Channel Fix Kit	18

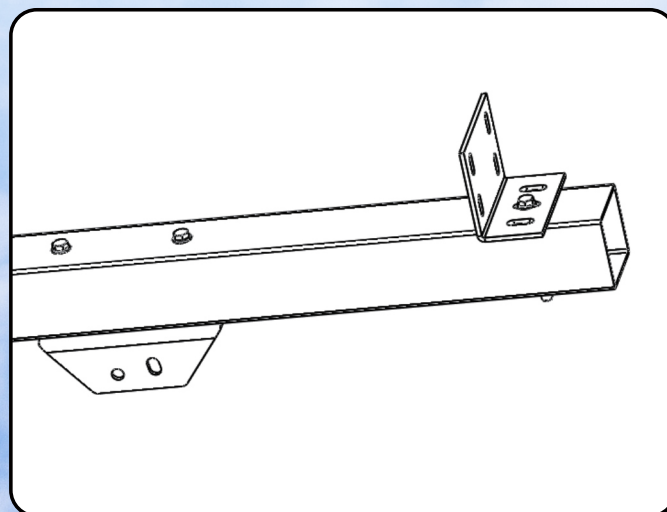
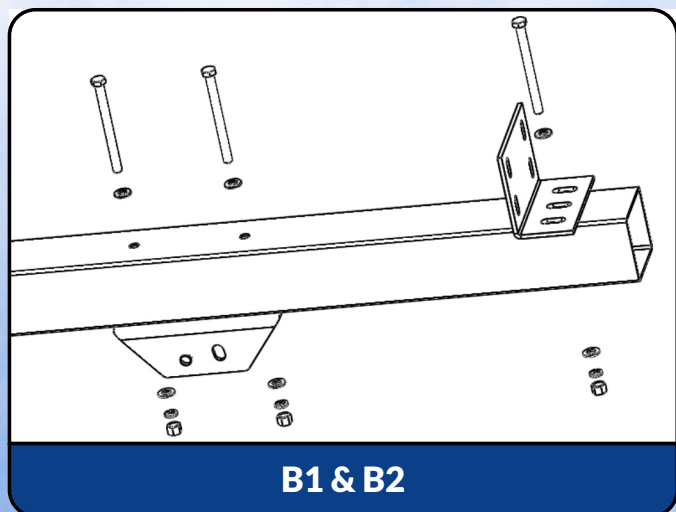
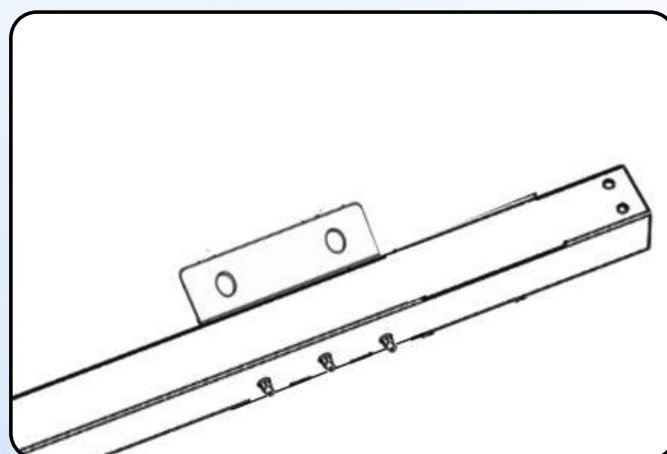
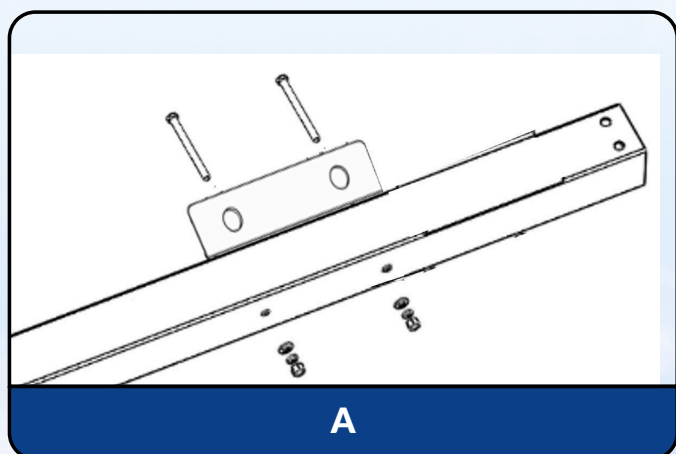

## 4. Connect Columns

- ✓ Attach Columns to base plate

Products Name	Quantity
Front Columns --- 111"	3
Rear Columns --- 126 ½"	3
M16 *180mm Bolt Kits (1 flat washer + 1 spring washer + 1 nut)	24

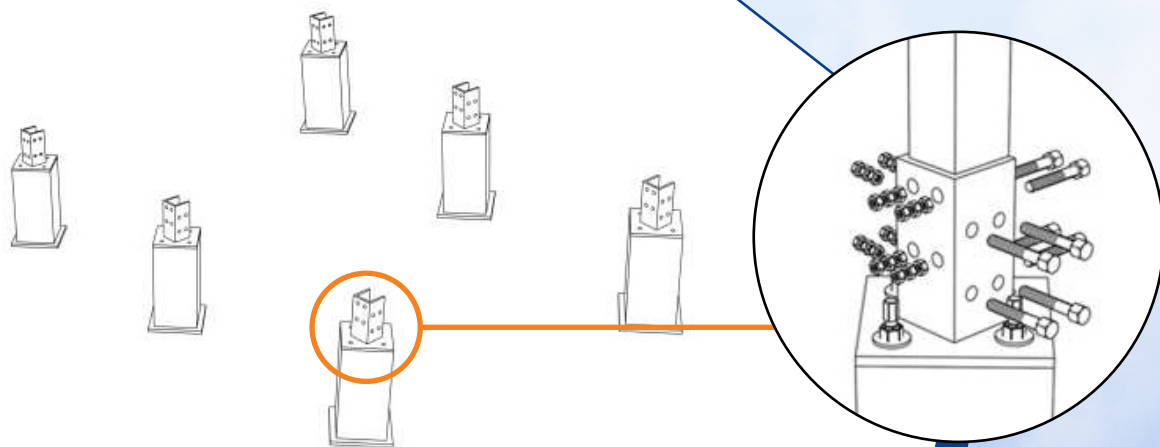



## 5. Connect Beams

- ✓ Connect Lower Horizontal Beam to front and rear Columns
- ✓ Connect Support Beam between front and rear columns on top
- ✓ Connect Diagonal Brace between Support Beam and Column

Products Name	Quantity
Lower Horizontal Beam 168 <sup>1</sup> / <sub>16</sub> "	3
Top Support Beam 228 <sup>5</sup> / <sub>16</sub> "	3
Diagonal Brace 47 <sup>3</sup> / <sub>16</sub> "	6

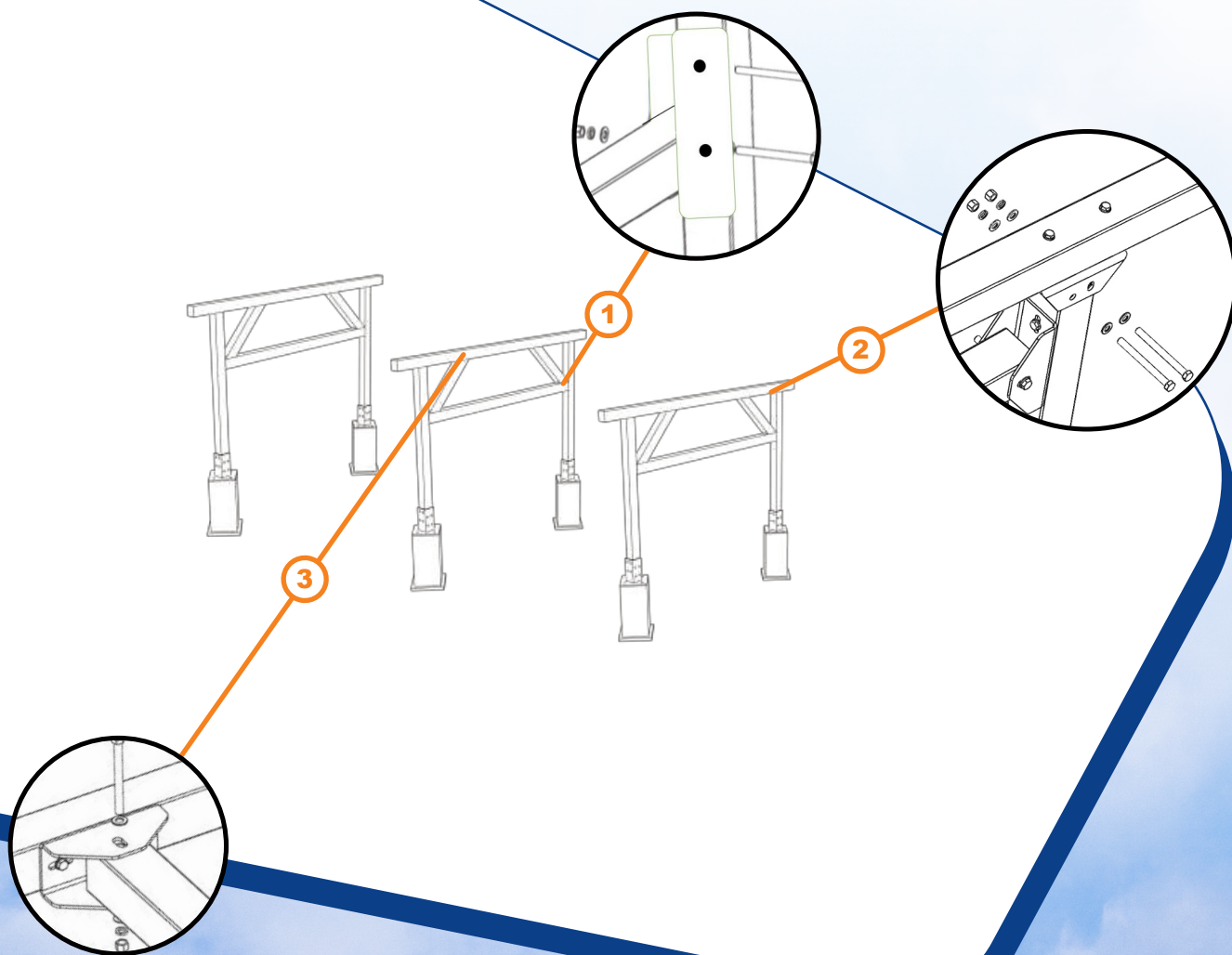

## 6. Fix C Channel

- ✓ Combine C-Channels with C-Channel Splice Kits
- ✓ Use C-Channel Fix Kit to connect C-channels to Top Support Beam
- ✓ Use M10\*16mm Bolt Kits (1 flat washer + 1 Spring Washer + 1 Nut)
- ✓ Use M10\*25mm Bolt Kits (1 flat washer + 1 Spring Washer + 1 Nut)

Products Name	Quantity
C Channel --- 220 1/2"	6
C Channel --- 63"	6
C-Channel Fix Kit	18
C-Channel Splice Kit	12
M10 180mm Bolt Kits (1 flat washer + 1 spring washer + 1 nut)	120
M16 180mm Bolt Kits (1 flat washer + 1 spring washer + 1 nut)	120

\*When spliced, total length of C-Channels is 283 1/2"

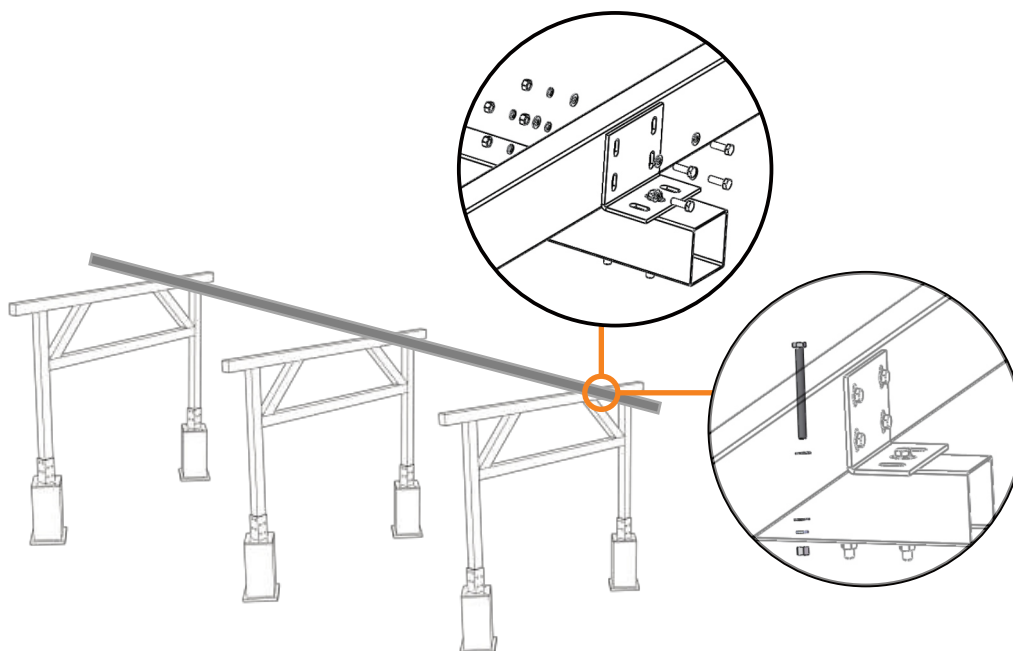



## 7. U-Rail Construction

1. Connect 2 U-Rails using the U-Rail Splice. The U-Rail will have pre-drilled holes at the ends of the U Rails where the splice connects using Hex Bolt M10\*30 Once the U-Rails are connected the rail count will be 13qty. The U-Rail will also have 6 existing holes that will line up with the top of the C-Channels.

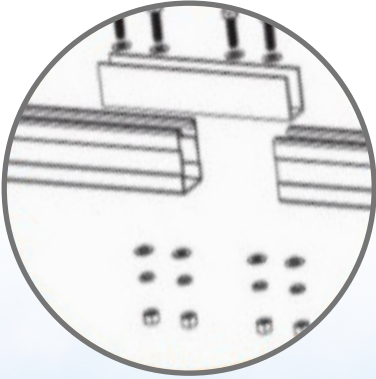

Products Name	Quantity
U-Rails 137 <sup>3</sup> / <sub>4</sub> "	14
U-Rail Splice Kits	7
Mid Clamps	60
End Clamps	24
M10*30 Bolt Kits	72

### U-Rail Configuration

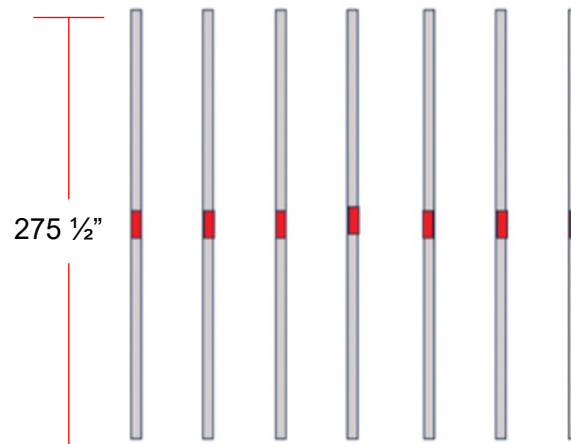

■ = Splice Location

## 8. Fix U Rail

1. Determine your 1st U-Rail attachment location on top of the C-Channels by utilizing the attached Math Module Placement Guide (you can start at either end) Your module width will determine your U-Rail attachment location. Once you determine the starting point for the 1st U-Rail ensure the starting distance is equal on the top C-Channel And the bottom C-Channel. You can mark all holes and drill C-Channel connection points.
2. Once your 1<sup>st</sup> U-Rail is secure, place end clamps into this U-rail.
3. Place a second U-rail on top of the C-channels with Mid-Clamps installed. Do not secure 2nd U-rail to C-channels until you verify the mounting distance between U-Rails is correct. Verify mounting distance Between U-Rails by mounting one module and ensuring proper spacing between of U-rails. The module should fit tight and should be square. Once verified attach 2nd U-Rail to C-channels using 6 Hex Bolts M10\*30.
4. Install the remaining 11 U-rails connected and spliced U-Rails on top of C-Channels using 6 Hex Bolts M10\*30 for each U-Rail.
5. If waterproofing, with U-Rail Gasket, do NOT install panels until waterproofing is complete.
6. Place all modules on top of carport tightening end and mid clamps to provided torque specs.

Please Review Math Calculation in Appendix

Products Name	Quantity
U Rails 137 <sup>3</sup> / <sub>4</sub> "	14
M10*30	72

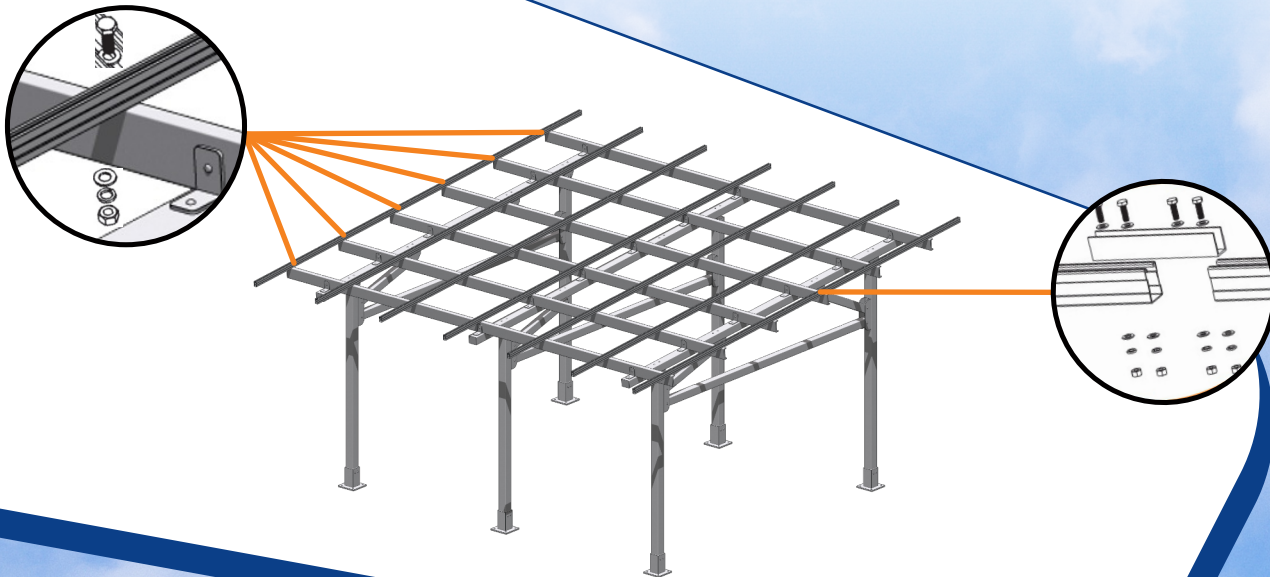



## 9. Install L-Angle Supports

L-Angle supports provide continuous stability and reduce any twisting or settling that may occur within the C-channel system. The L-Angle supports are attached to the bottom-center of the C-Channels using M8 screws. Each L-angle support will be attached with 6-qty M8 screws at 6 separate contact points on six separate C channels. The L-Angle support will run Perpendicular to the C-Channels and parallel to the Top Support Beam. The L-Angle supports will be installed in the center of each car bay (See Diagram Below).

Products Name	Quantity
L-Angle Support 224 <sup>1</sup> / <sub>16</sub> "	2
M8 Screws	12

### L-Angle Support Installation Locations

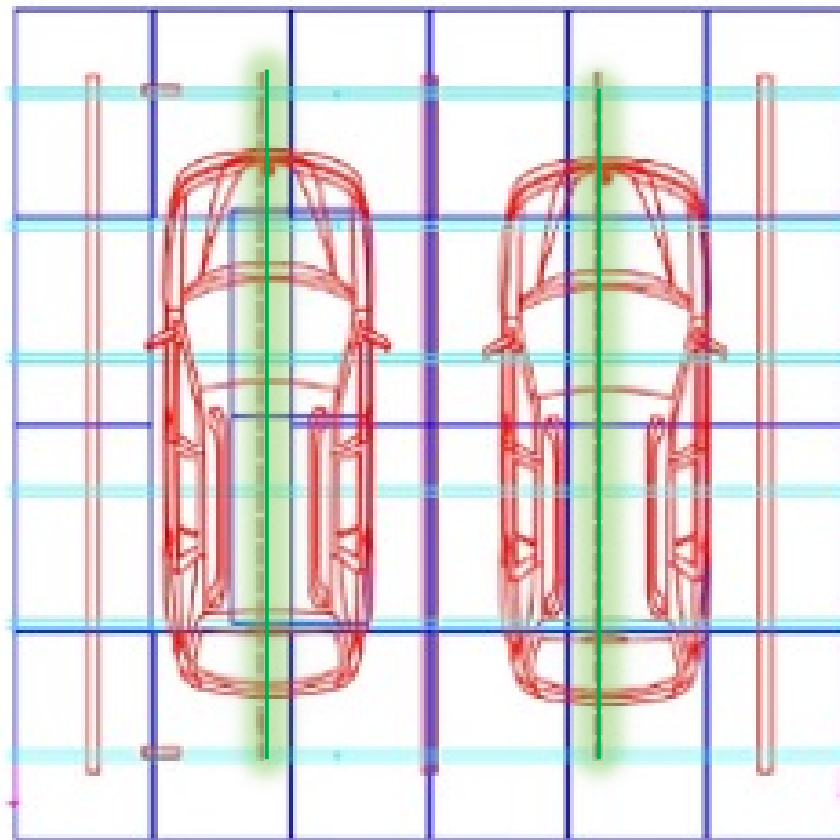

— = L-Angle Support

## 10. Install Solar Panels (With or Without Waterproofing)

**NOTE: The peel and stick rubber stripping is different than the Rubber Panel Gasket, the Rubber Panel Gasket is much bigger and thicker.**

**For Installation Without Waterproofing** - Select a start point at one of the four corners, tightening the end clamps only to hold the module in place. Install one complete column of 3 or 4 modules (depending on your array size). Now install adjacent column by tightening the adjoining Mid clamps. Repeat this same process until all modules are installed. (Note: Tighten all end and mid clamps to torque specs.)

**For Installation With Water Proofing** - If using the rubber stripping for waterproofing, measure the width of the panel and cut the stripping to fit on the short side of the panel. Once cut, peel the paper off of the rubber stripping exposing the sticky adhesive. Place the sticky adhesive on the short side of the selected panels. Use 1 strip per seam or joint where 2 panels meet on the short sides of the panels. Do not apply more than one rubber strip per seam (every 2 panels gets 1 seam). Panels will share 1 rubber strip at locations where panels meet.

Once the Rubber Strip is attached, start the panel installation by placing one panel on top of the U-Rails, at one of four carport corners and tighten the end clamps. Repeat rubber stripping installation process for next panel. The next panel installed will be placed above or below the 1st panel installed depending on where you started, also only tighten the end clamp. Complete one column of panels 3 or 4 high, only tightening the end clamps. Once you have one column complete begin the next column installation with the column adjacent to the first column installed. Once the adjacent panels are placed next to the first column, tighten the mid clamps associated with the two columns.

Once 2 columns of panels are installed and mid clamps are all tightened to torque specs install the Rubber Panel Gasket in the seam that runs parallel to the U-Rails. Measure and Cut the Rubber Panel Gasket in order to accommodate for the Mid Clamp locations. Once measured and cut push the Rubber Panel Gasket down between the panel gap. Complete this process for all of the open gaps between panels. Ensure installation of Rubber Panel Gasket occurs after every interior column is installed to allow for physical access to the open gaps between panels that is to be covered by the Rubber Panel Gasket. The Rubber Panel Gasket will only be installed on the interior gaps that are running parallel with the U-Rails, on top of adjoining panels. Gently push the Rubber Panel Gasket down between panels until the top of the Rubber Panel Gasket is seated on top of the panels. There should be no gap between the bottom sides of the Rubber Panel Gasket and the top section of the panel frames.

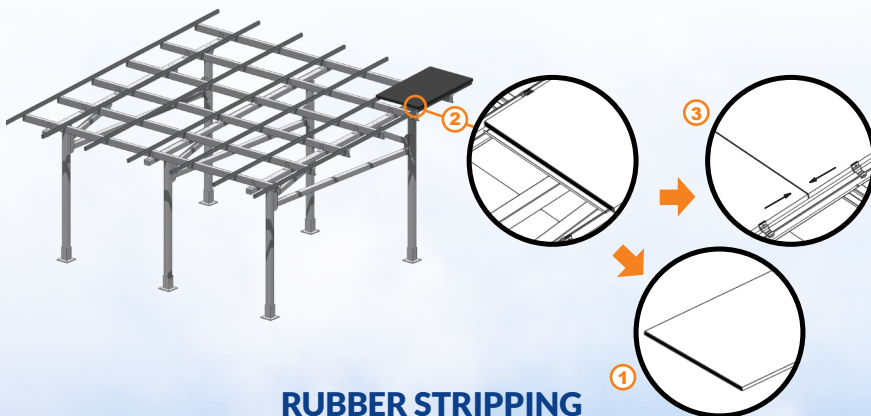

**RUBBER STRIPPING**

Products Name	Quantity
Modules	18 or 24
Rubber Stripping	1 Roll
Rubber Panel Gasket	1 Roll

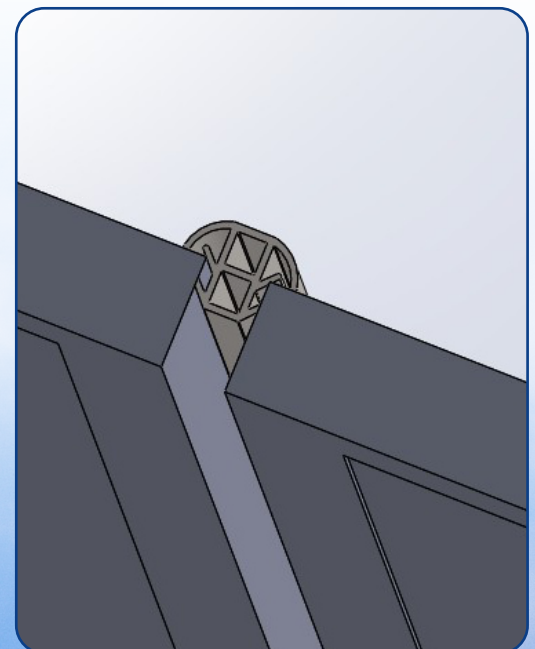

**RUBBER GASKET**



## 11. Grounding- Lug and Wiring

Install grounding lug at end of C-Channel on side of array that is most optimal for wire management. Ensure that all paint and any debris is removed from bonding site to achieve proper bonding connection. Attach each ground lug with a stainless steel nut then cross 8.4mm<sup>2</sup> or greater than or equal to 8AWG copper wire through all 6 grounding lugs (fixed by M8\*20 inner hex bolt), finally connect copper wire to the ground. The grounding lug completes a grounding function when fastened tight to connect all 6 C-Channels and copper wire.

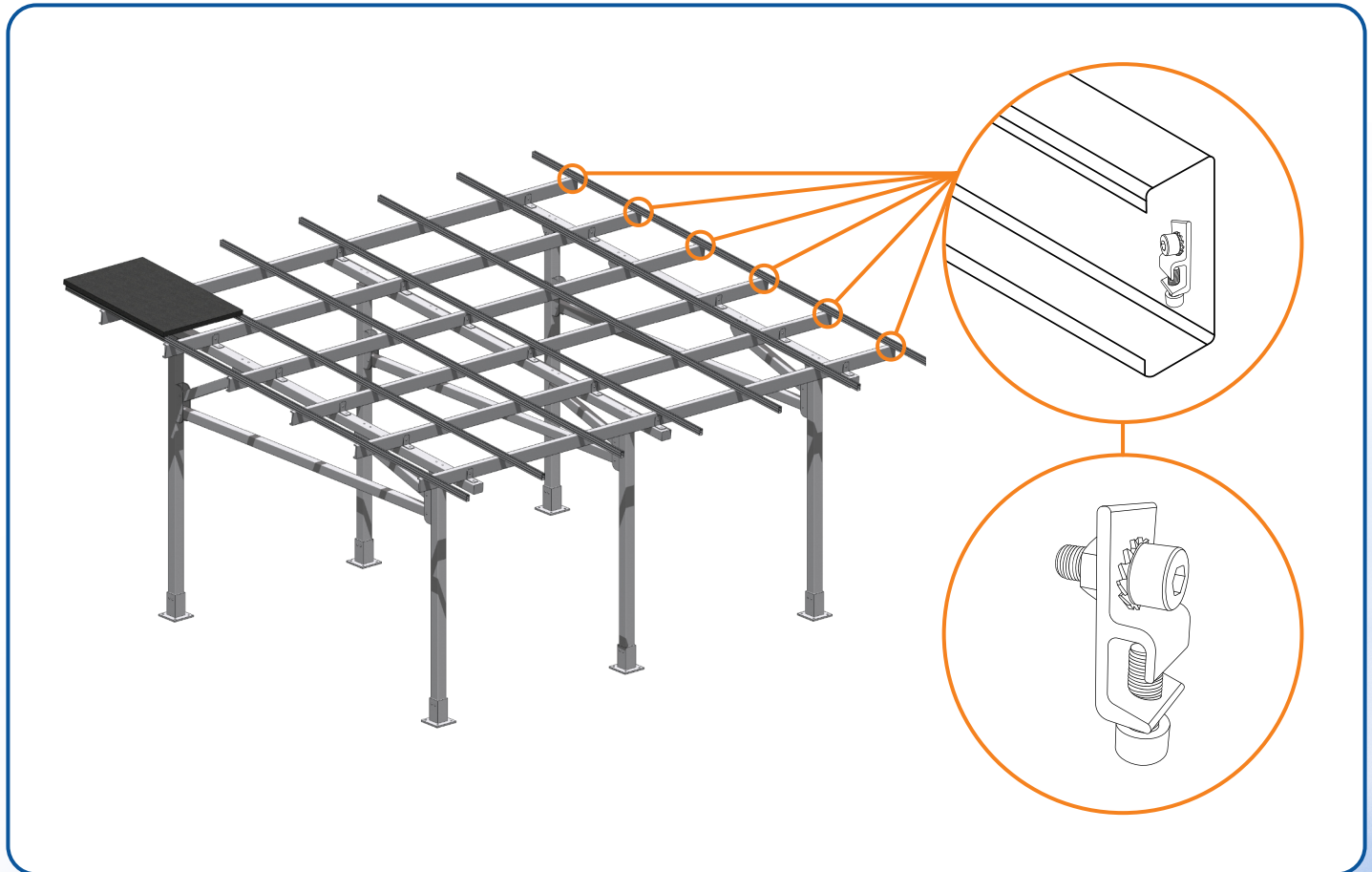

### Electrical Characteristics of AWG Copper Wire

AWG	Diameter [inches]	Diameter [mm]	Resistance [Ohm / 1000ft.]	Resistance [Ohm / km]	Max Current [Amperes]	Max Frequency for 100% skin depth
6	0.162	4.1148	0.3951	1.295928	37	1100 Hz
7	0.1443	3.66522	0.4982	1.634096	30	1300 Hz
8	0.1285	3.2639	0.6282	2.060496	24	1650 Hz
9	0.1144	2.90576	0.7921	2.598088	19	2050 Hz
10	0.1019	2.58826	0.9989	3.276392	15	2600 Hz

## Grounding - Lug and Wiring Diagram

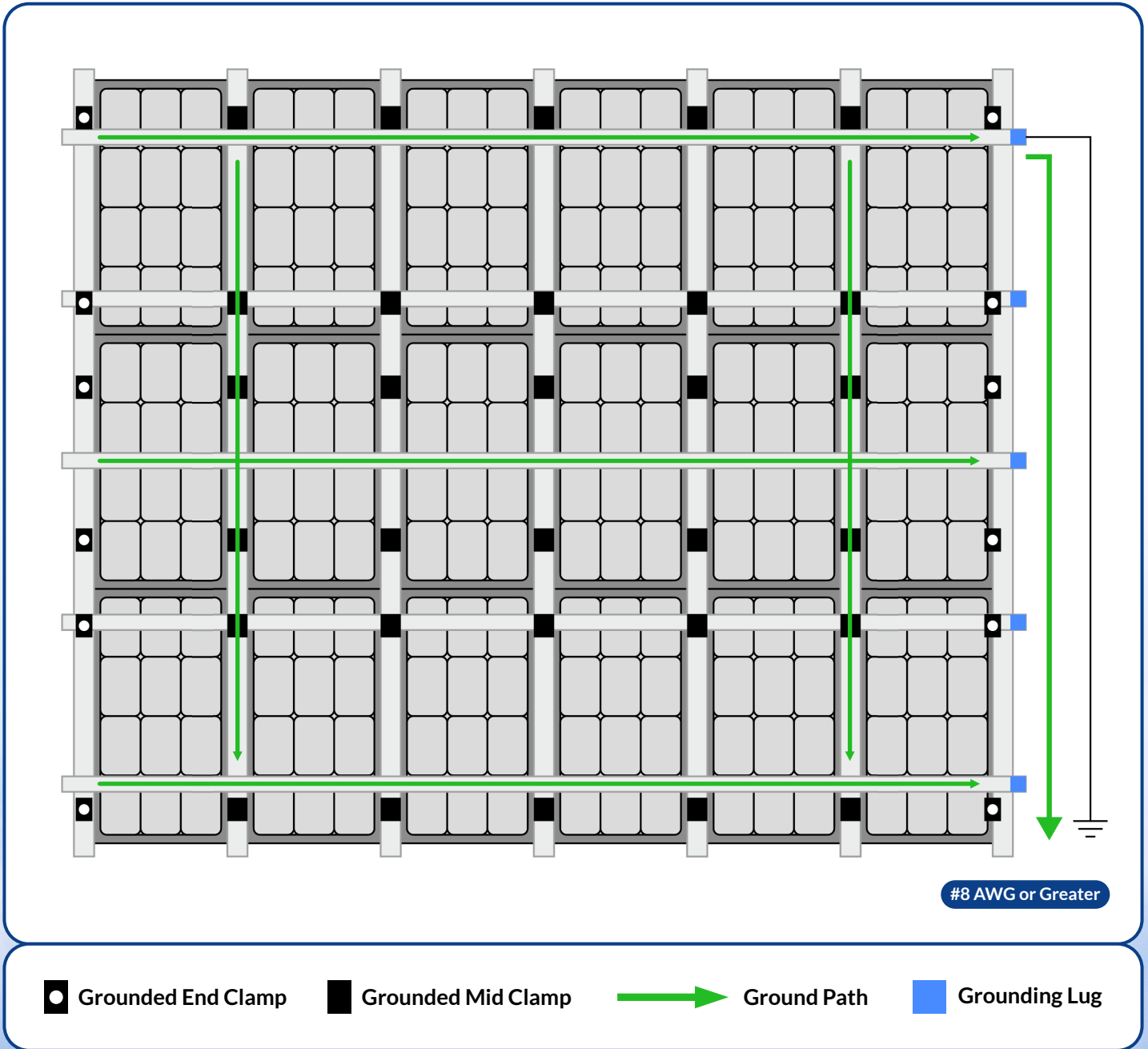

## 12. Final Check

- ✓ Check and verify that all components are properly fastened and installed properly in their correct positions and locations.
- ✓ Verify and re-adjust all components as needed within the structure.

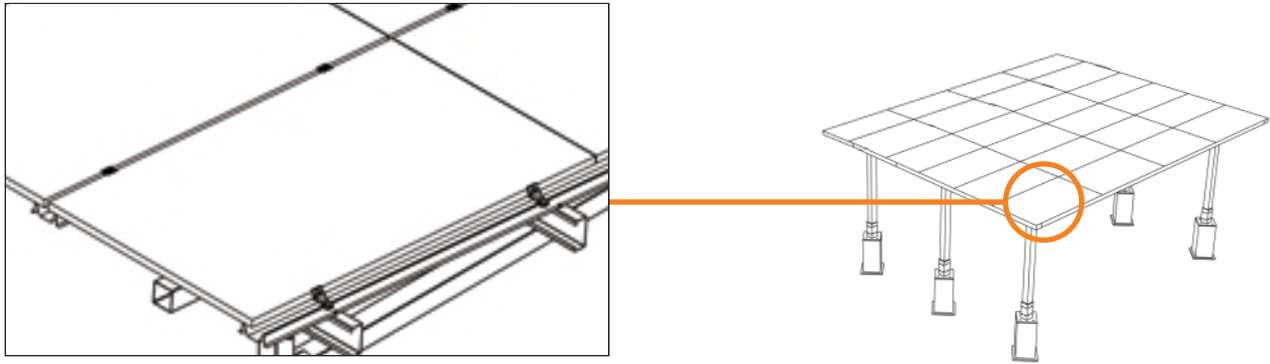

## 13. Hide Footing (Optional)

- ✓ Cladding of 4 bases is an option with engineer approval.

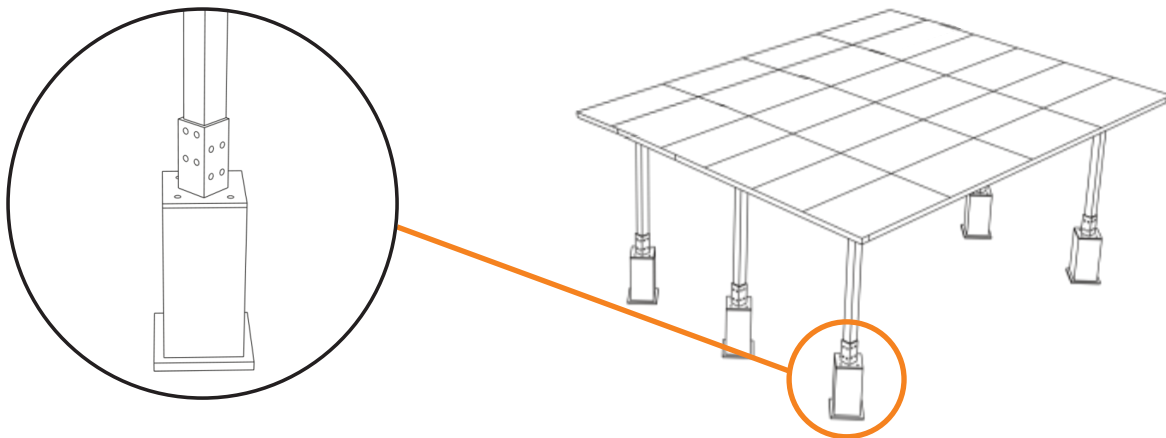



## TORQUE SPECIFICATION - CARPORT

	Grounding Lug	Fix M Rail to C Purlin Screw M6.3 X 25	Mid/End Clamp M8	C Rail Splice Kit M 10 * 30	Rail Fix Kit to Column M16	Rail Fix Kit to C Rail M10	Structure (incl Column Adapter, Base Plate M16
<b>Torque in N-m</b>	<b>6</b>	<b>12</b>	<b>16</b>	<b>28</b>	<b>30</b>	<b>34</b>	<b>40</b>

Note : The above values are expressed as N-m,- "Newton-meter"

	Grounding Lug	Fix M Rail to C Purlin Screw M6.3 X 25	Mid/End Clamp M8	C Rail Splice Kit M 10 * 30	Rail Fix Kit to Column M16	Rail Fix Kit to C Rail M10	Structure (incl Column Adapter, Base Plate M16
<b>Torque in ft/lb</b>	<b>4.5</b>	<b>9</b>	<b>12</b>	<b>21</b>	<b>22.5</b>	<b>22.5</b>	<b>30</b>

Note : The above values are expressed as "foot-pound"

# WORLDLEADING

## M A N U F A C T U R E

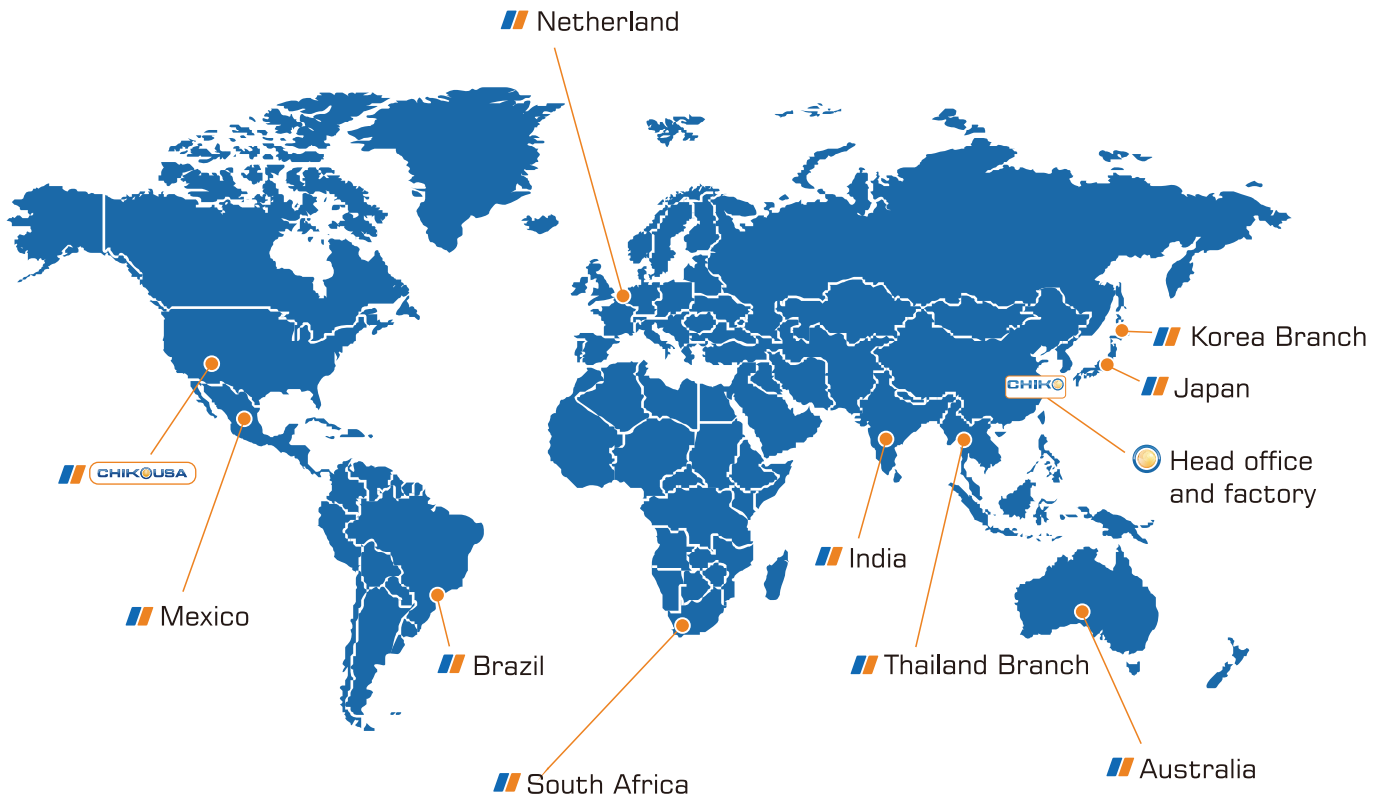

**CHIKOUSA**  
RACKING MADE SIMPLE

Tel : 1-800-948-5390

Email : [info@chikousa.com](mailto:info@chikousa.com)

[www.chikousa.com](http://www.chikousa.com)



101 East Baseline Road  
Buckeye, AZ 85326

# MAXIMO 185 TWO CAR CARPORT

**Panel Layout : 4x6**

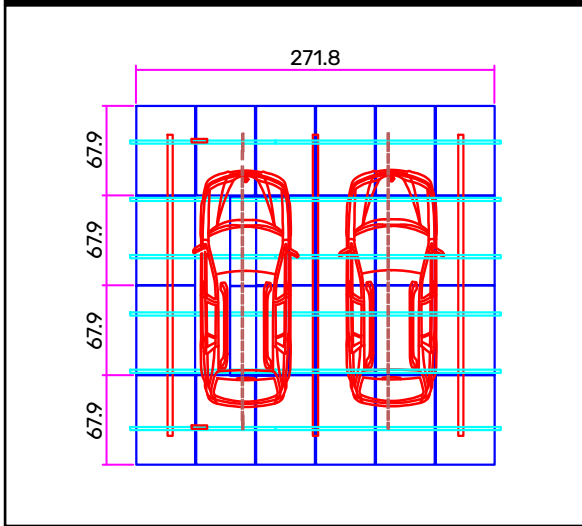

**C Channel Layout**

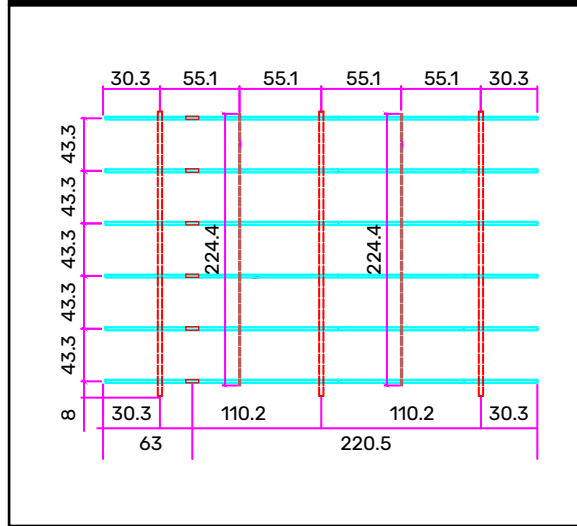

**C Channel & U Rail Layout**

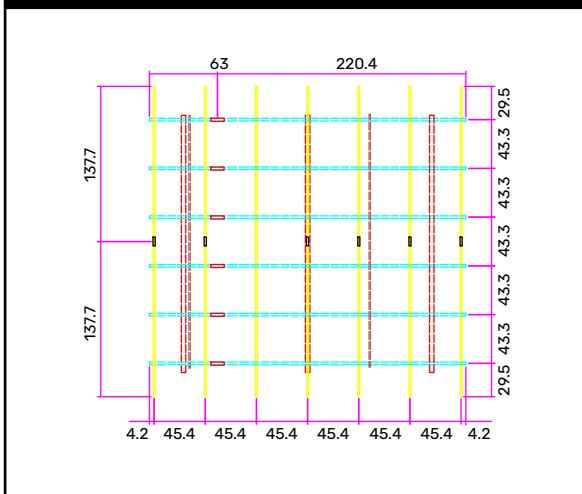

**Foundation Layout**

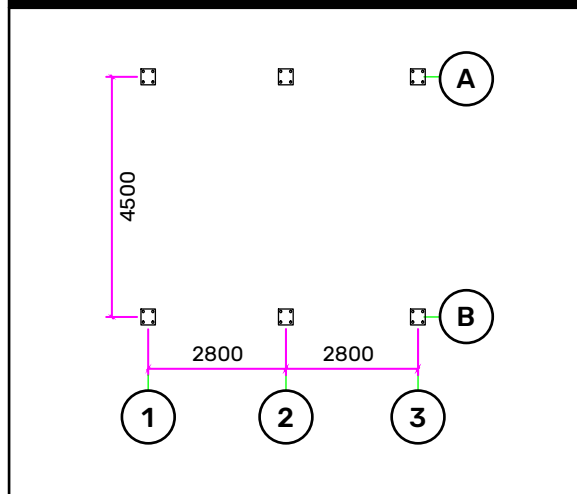

**Layout : 4x6**

**BOM**

NO	DESCRIPTION	QTY
1	Support Rack	3
2	End Clamp	24
3	End Clamp share plate	24
4	Mid Clamp	60
5	Mid Clamp share plate	60
6	C Rail fix kit	30
7	C-Channel 220 1/2"	6
8	C-Channel 63"	6
10	C-Channel Splice	6
11	U-Rail 137 3/4"	14
12	U-Rail Splice	7

Design Factors :  
 Module Dimensions : 1724\*1134\*34  
 Tilt Angle : 5°  
 Front Clearance : 111  
 Wind Speed : --  
 Snow Load : --

Modify by	Doc No.	Data	Des	J. Burton	241105
			Drw		
			Check		
			Craft		
			App		

**CHIKOUSA**

Maximo 185

Maximo185 2-Car

4x6-5°

View :

Rate

Page /



# MAXIMO 185 TWO CAR CARPORT C-CHANNEL SPLICE LOCATIONS

 = SPLICE

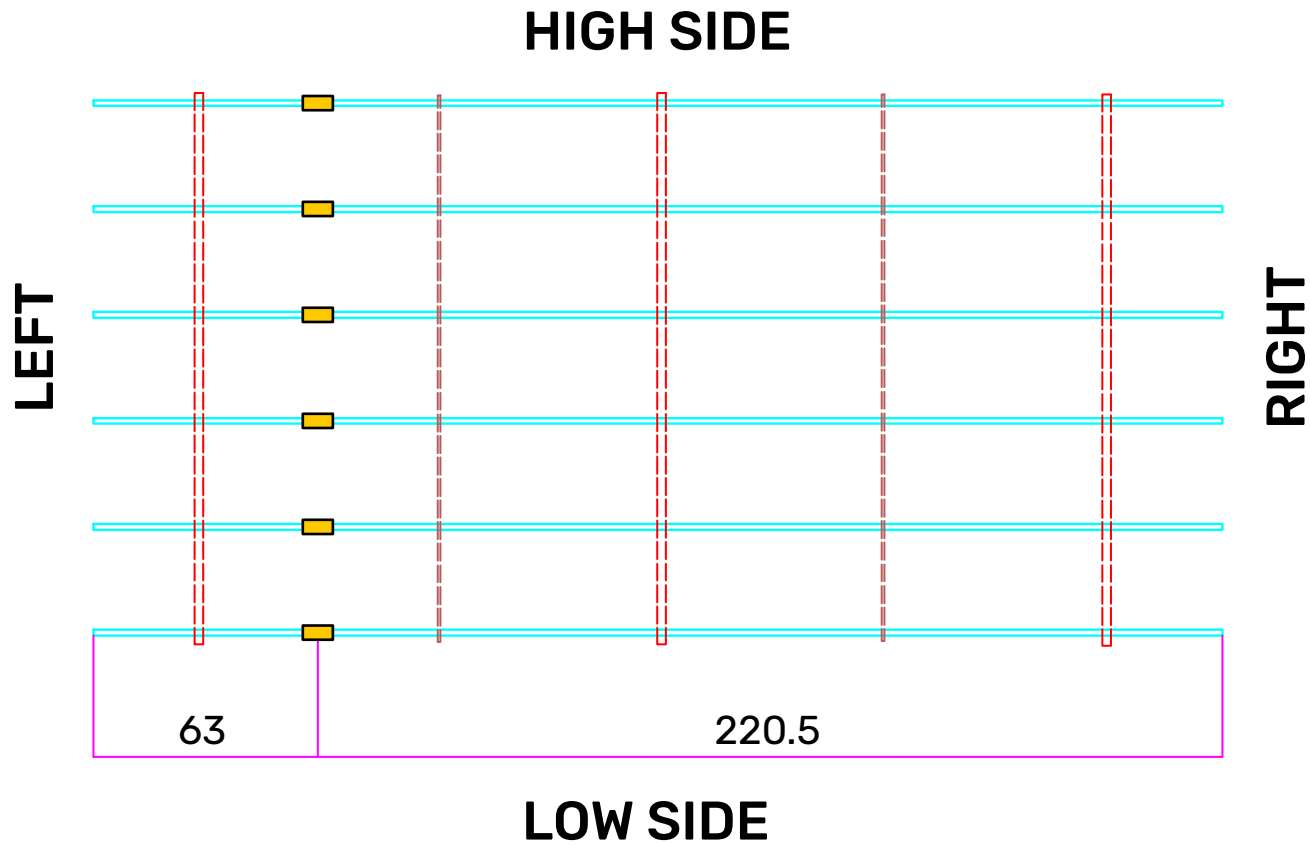

	Modify by	Doc No.	Data	Des	J. Burton	241105	<b>CHIKOUSA</b>		
				Drw					
				Check			Maximo185 2-Car		
				Craft			Splice Locations		
				App			View: 	Rate	Page /

# MAXIMO 185 TWO CAR CARPORT FOUNDATION LAYOUT

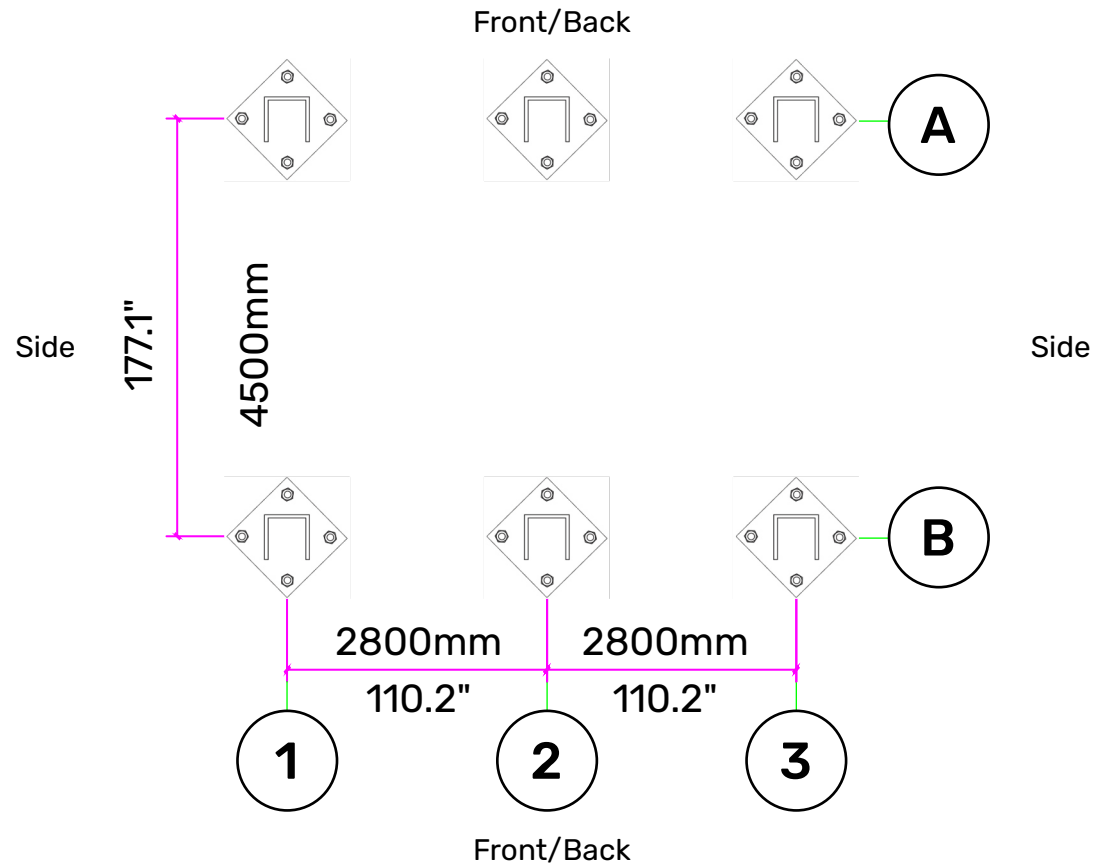

Note: Base Plates shown can rotate 180° based on aesthetic preference.  
The C opening can either face down (image shown) or up. The C-opening cannot face to either side

	Modify by	Doc No.	Data	Des	J. Burton	241105	<b>CHIKOUSA</b>	
				Drw			Maximo185 2-Car Foundation	
				Check				
				Craft			View :	Rate
				App				Page /

A

B

C

D

# CHIKO CARPORT BASE PLATE DRAWING - IN MM

270MM X 270MM

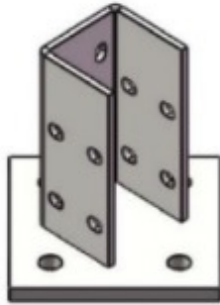

4- $\dot{y}$ 18\*25  
penetration

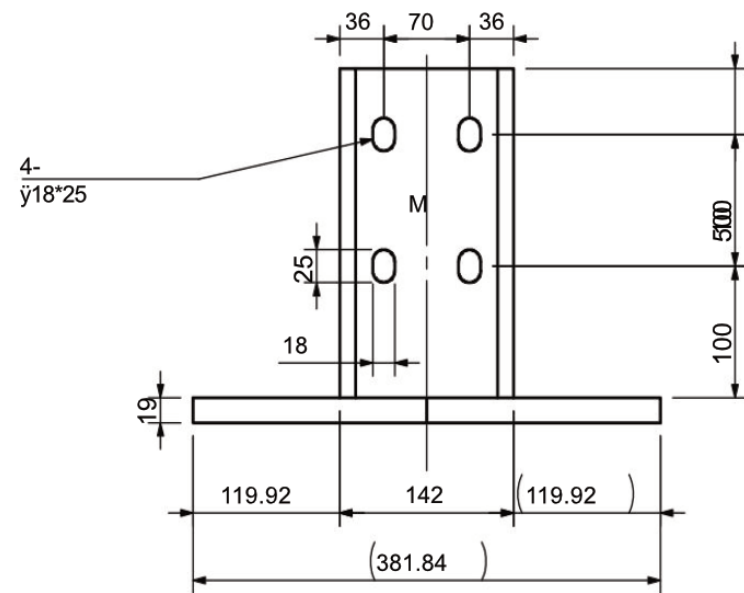
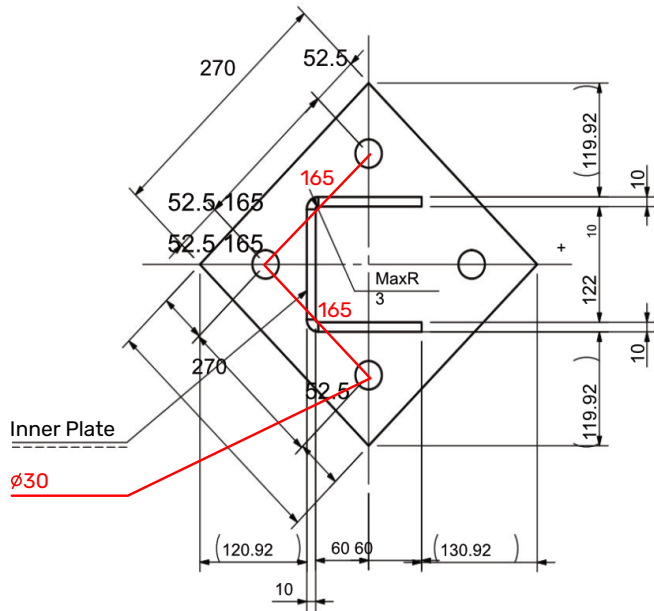
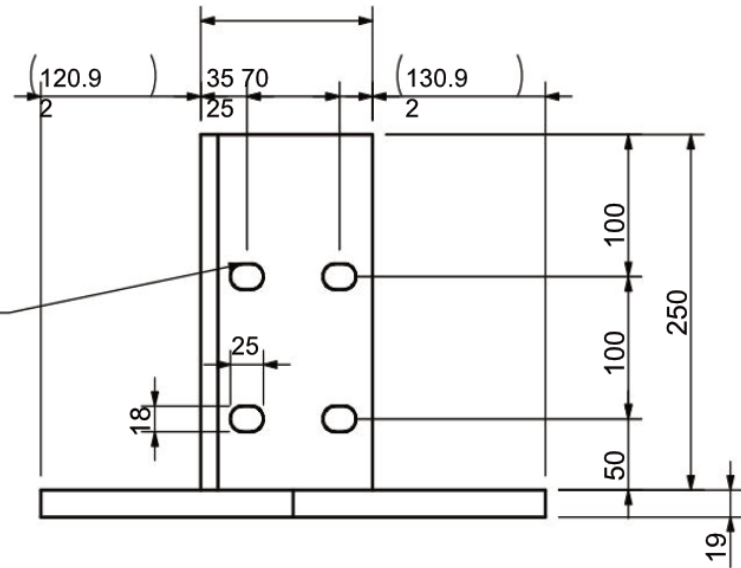

		Modify by	Doc No.	Data	Des	J. Burton	241105	<b>CHIKOUSA</b>		
					Drw					Maximo185 2-Car
					Check			Base Plate		
					Craft			View:	Rate	Page /
					App					



# CHIKOUSA Carport Base Plate

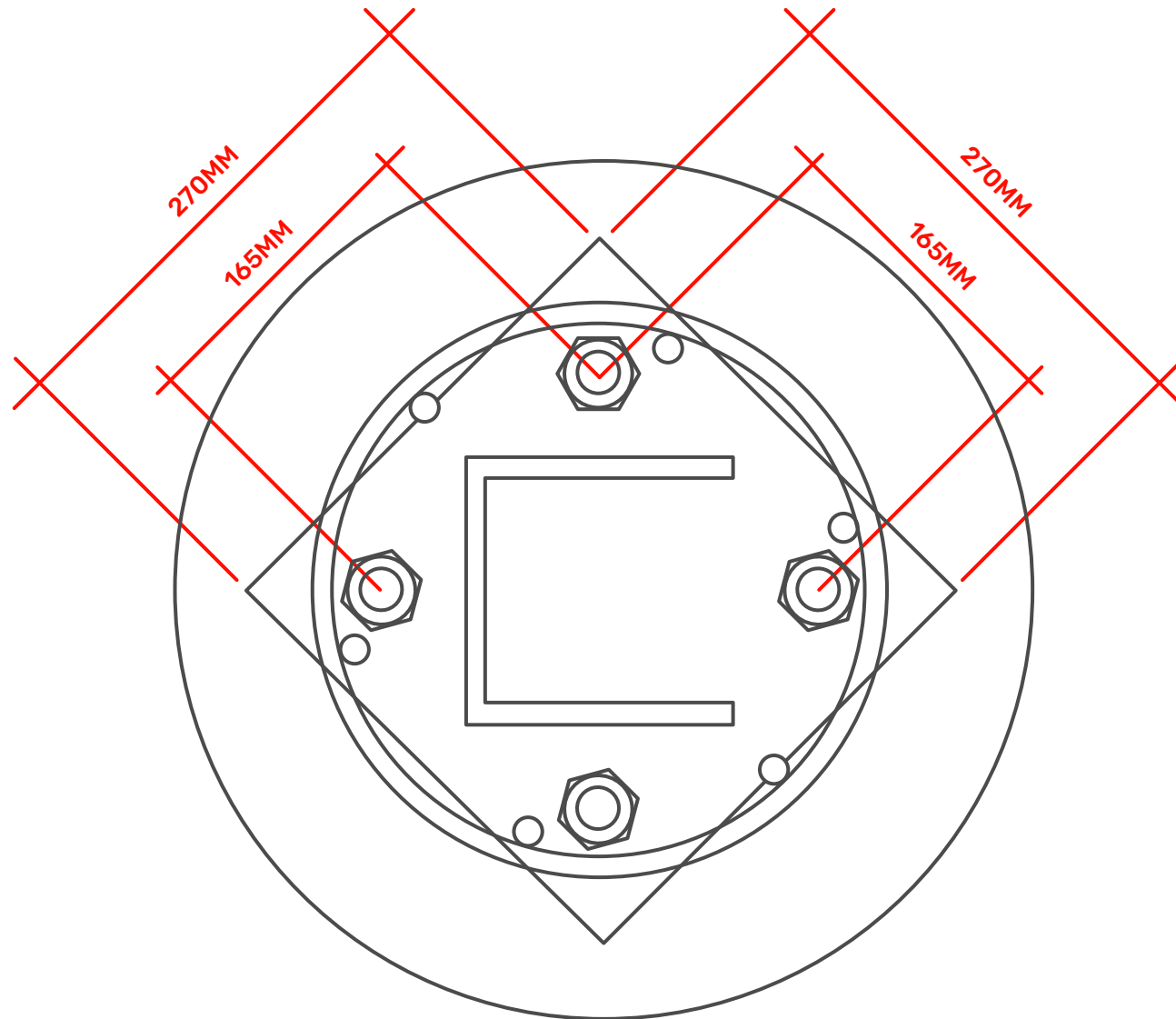

Bottom Holes M-30

**Note: Base Plate Will Be Installed At 90 Degree Angle to the Structure**

# SIDE PROFILE AND PARTS DIAGRAMS

(Please note: the open side of the C-Channel faces the high side of the Carport)

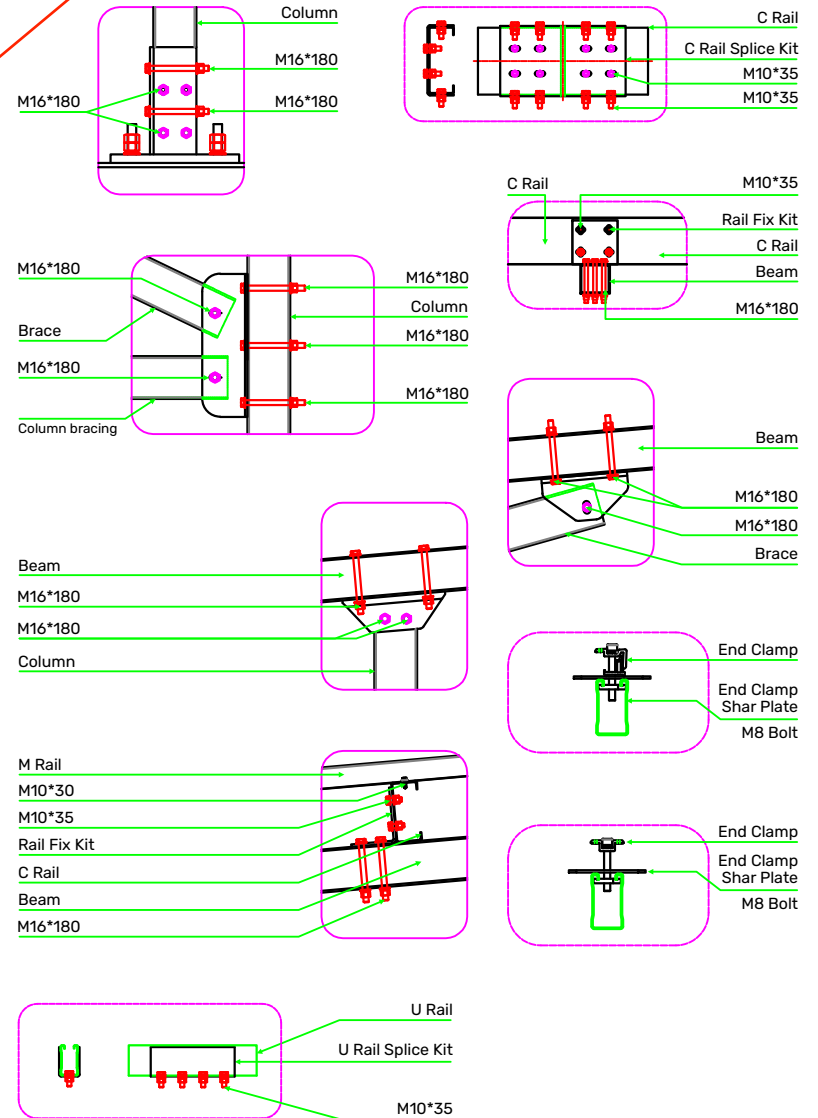
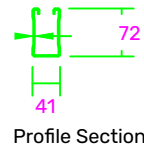
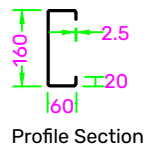
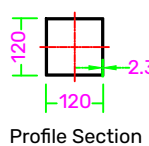
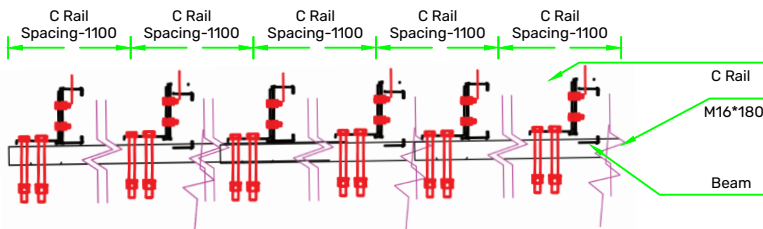
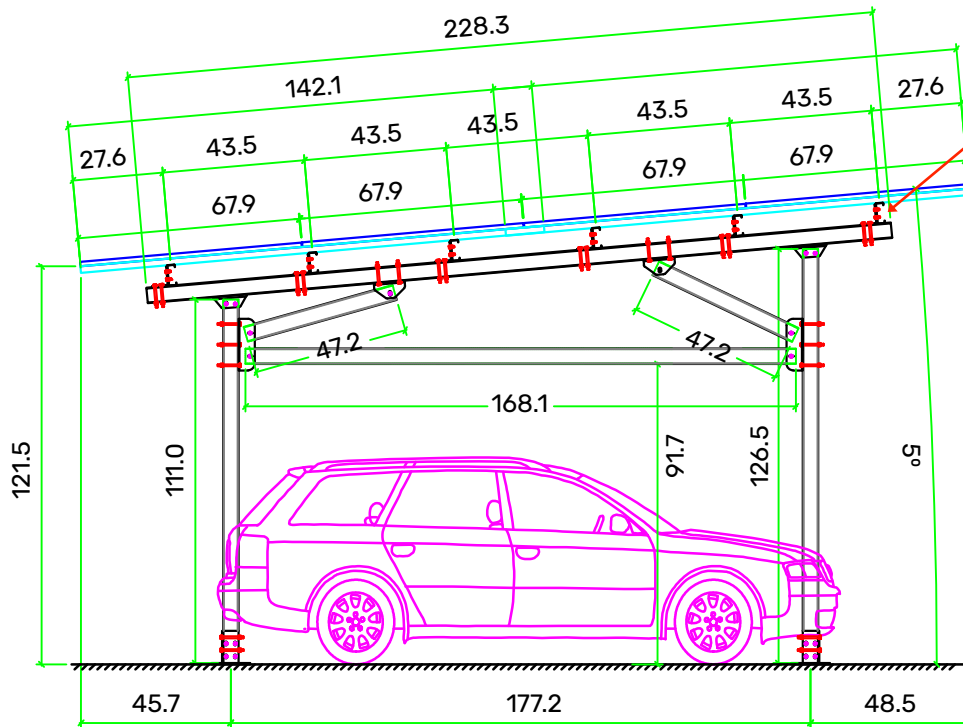

Design Factors :  
 Module Dimensions : 67.9 x 44.6  
 Tilt Angle : 5°  
 Front Clearance : 111  
 Wind Speed : --  
 Snow Load : --

Modify by	Doc No.	Data	Des	J. Burton	241105
			Drw		
			Check		
			Craft		
			App		

**CHIKOUSA**

Maximo185 2Car

Side Profile + Parts

View :

Rate

Page /