

CHIKOUSA

CK- | STEEL SOLAR CARPORT | GAZEBO

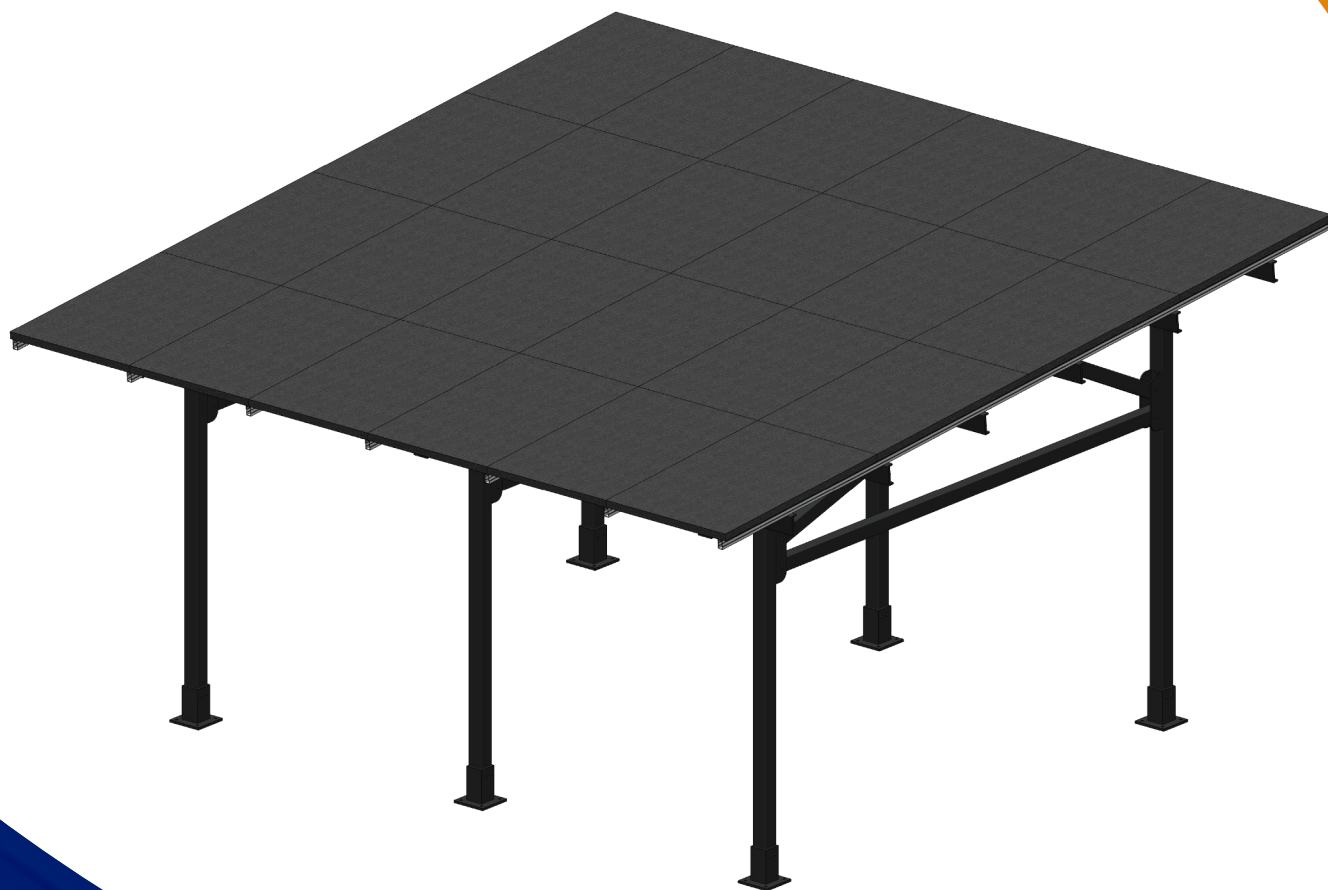

MAXIMO-185 (2-CAR) STEEL SOLAR CARPORT | GAZEBO INSTALLATION MANUAL

VERSION: 11.01.24 | ENG

Always use the most recent version of the installation manual before installing your Carport/Gazebo. The installation Manual is subject to change without notice. Please consult with CHIKOUSA to ensure you are utilizing the latest Install Manual.

BRIEF DESCRIPTION

The CHIKOUSA Steel Carport/Gazebo is a robust solar carport that can accommodate a wide range of panel sizes, with a max (North/South or Up/Down) span of 270". This structure can be installed with a 2-3 person crew, without the need of any heavy duty tools. The Installation should always be completed by trained professional and/or qualified individuals, who have been adequately instructed and trained about the tasks involved with the installation, including the usage of protective devices, protective measures, relevant provisions, safety regulations and local operating site conditions and have proven competence in all areas of the installation.

Please read carefully this installation manual and all other applicable documents before starting your installation. Please contact CHIKOUSA with any questions that you may have.

MAINTENANCE

1. When signs of rust appear, or when the paint is peeled or removed, you must take steps to remove the rust and paint the affected areas.
2. You must check the bolts once a year ensuring all connections are secure, and after any major storm or weather occurrence. Tighten all bolts according to torque specs.
3. If the columns of the structure are hit, you must replace the columns of the structure immediately.

WARNING

If any structural component of the system to include the column, beam, base plate, or rail are damaged they must be replaced immediately.

FOOTER WARNING

Anyone who plans to dig should call 811 or visit their state's 811 center's website a few business days before digging to request that the approximate location of buried utilities be marked with paint or flags so that you don't unintentionally dig into an underground utility line.

MEASUREMENT NOTE

Some measurements have been converted from MM to Inches. The accuracy of measurement can vary slightly from mm to inches. Some measurements are available in MM for detailed accuracy. The most critical measurement required is the Base Plate placement location. Please review the Construction Drawings for the Base Plate and Base Plate locations prior to installation.

REQUIRED INSTALLATION TOOLS

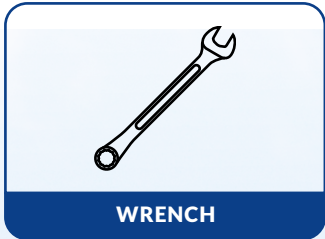
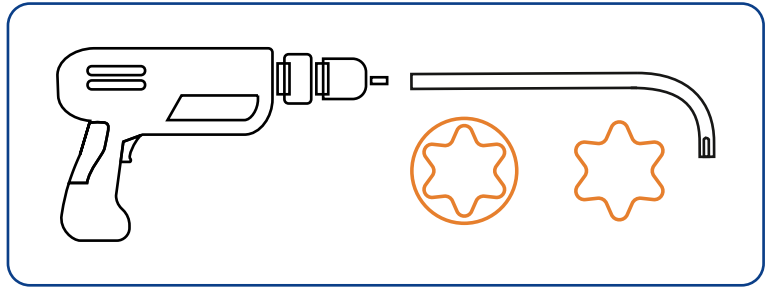
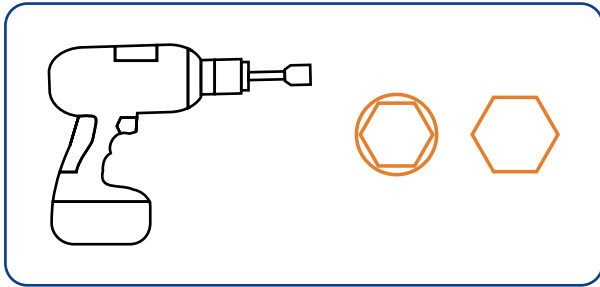

WRENCH



GLOVES

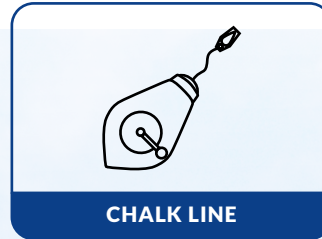

CHALK LINE

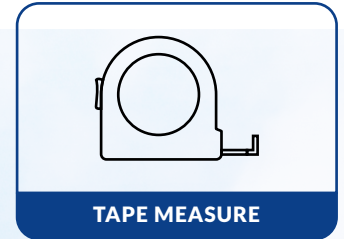

TAPE MEASURE



RUBBER MALLET



HARDHAT



SAFETY GLASSES

MAIN COMPONENTS



137³/₄"

U RAIL

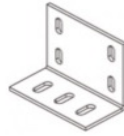

C-CHANNEL FIX KIT

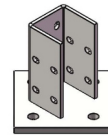

BASE PLATE



7⁷/₈"

U-RAIL SPLICE

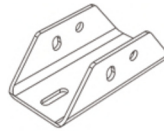

10³/₁₆"

TOP COLUMN ADAPTER

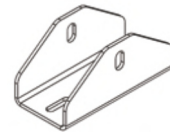

10³/₁₆"

DIAGONAL BRACE ADAPTER

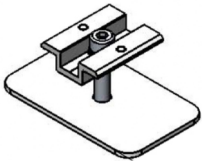

MID-CLAMP

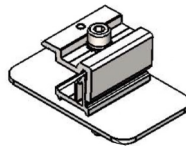

END-CLAMP



U-RAIL GASKET



WATER-PROOF RUBBER

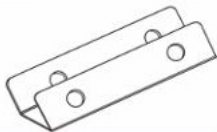

16¹/₂"

LOW BEAM/DIAGONAL BRACE ADAPTER

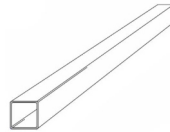

111"

FRONT COLUMN

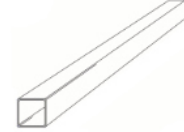

126¹/₂"

REAR COLUMN



224⁷/₁₆"

L-ANGLE SUPPORT



228⁵/₁₆"

TOP SUPPORT BEAM

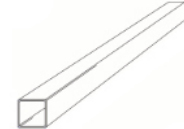

168 1/16"

LOWER HORIZONTAL BEAM

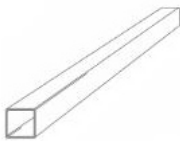

47¹/₄"

DIAGONAL BRACE

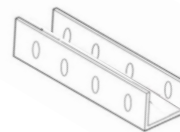

11¹³/₁₆"

C-CHANNEL SPLICE



220 1/2", 63"

C-CHANNEL

NOTE

Customer needs to source materials for footings based on structural engineer specifications.

MAIN COMPONENTS

Overview

The following is a diagram that lists the main components of the CK- Carport System.

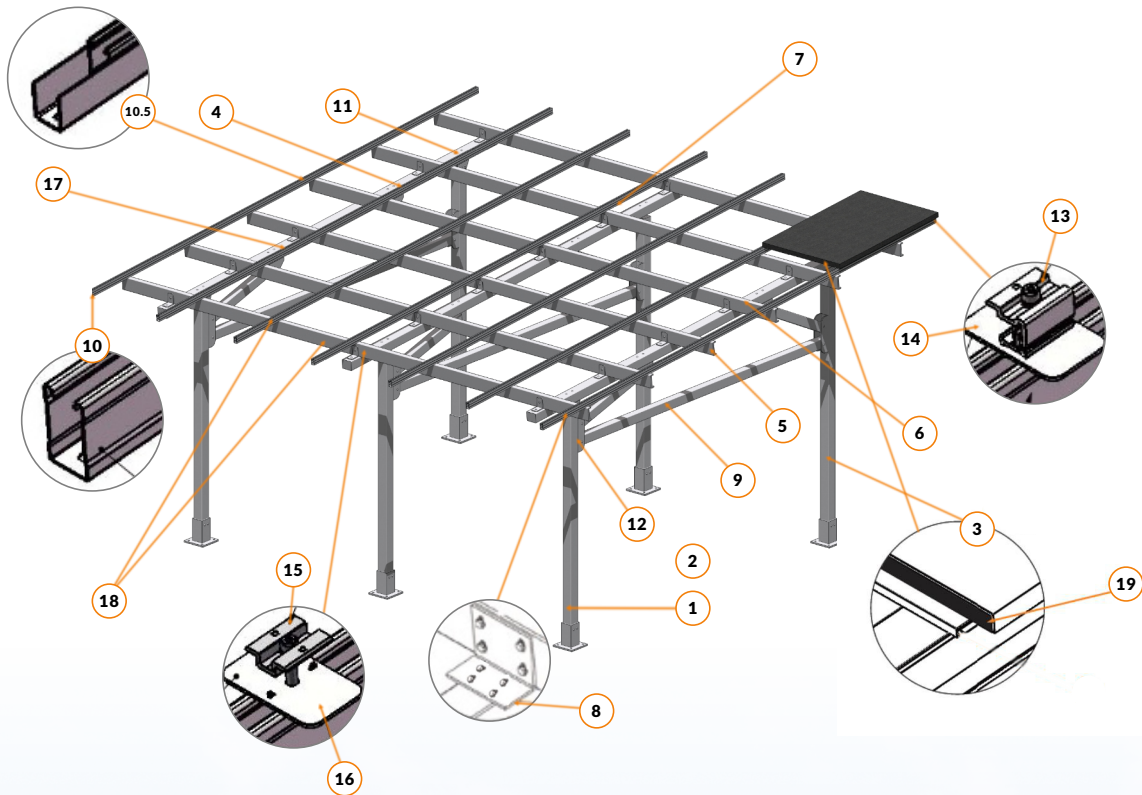

No	Description	QTY
1	Base Plate	6
2	Front Column 111"	3
3	Rear Column 126 1/2"	3
4	Top Support Beam 228 5/16"	3
5	Lower Horizontal Beam 168 1/16"	3
6	Diagonal Brace 47 1/4"	6
7	L-Angle Support 224 7/16"	2
8	C Channel Fix Kit	18
9	C-Channel 220 1/2"	6
	C-Channel 63"	
10	U-Rail 137 3/4"	14

No	Description	QTY
10.5	U-Rail Splice	7
11	Top Column Adapter 10 3/16"	6
12	Low Beam & Diagonal Brace Adapter 16 1/2"	6
13	End Clamp	24
14	End Clamp Share Plate	24
15	Mid Clamp	60
16	Mid Clamp Share Plate	60
17	Diagonal Brace Adapter 10 3/16"	6
18	C-Channel Splice	6
19	Waterproof Rubber	



FRONT VIEW



SIDE VIEW

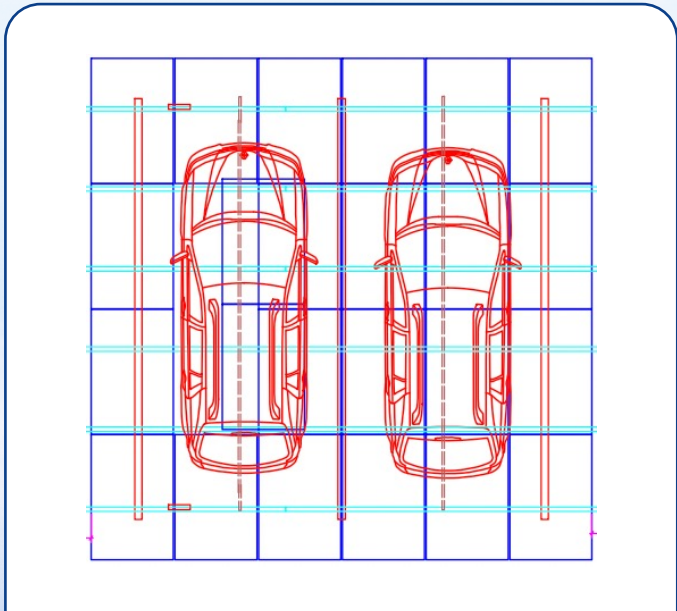







OVERHEAD VIEW

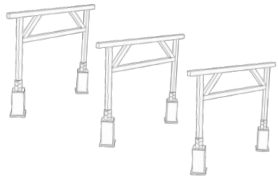

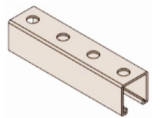
18 OR 24 SOLAR PANELS

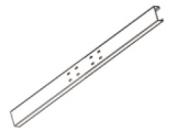
COMPONENTS LIST

CAT	Picture	Description Part	Details	QTY
1		Carport Support Structure	Front Columns	3
			Rear Columns	3
		CK-ZEM-CP3-5	Base Plate	6
			Top Support Beam	3
		<u>COLUMNS</u> CK-001-016-014	Top Column Adapter	6
			Lower Horizontal Beam	3
		<u>BEAMS</u> GT-001-016-014	Diagonal Brace	6
			Low Beam & Diagonal Brace Adapter	6
		Base 'Plate' CK-GT-001-016-805	HDG Bolt M10*35	168
			HDG Bolt M16*180	158
		GT-001-016-805	HDG Nut M10	168
			HDG Nut M16	156
		Column/Beam Adapters	HDG Washer M10	168
			HDG Washer M16	156
		Beam CK-GT-001-016-014	HDG Spring Washer M10	336
	HDG Spring Washer M16	312		
Column CK-001-016-014				
2		U Rail CK-ZEM-U72-2.5-3500	U Rail 137 3/4"	14
			M-10 30 Nut & Bolt Set	42
3		U Rail Splice CK-009-1062	U Rail Splice	7
4		Water Proof Strip CK-IP-160-1133	Water Proof Rubber	
5		'C' Channel CK-PL-C140-001-016-6000	C-Channel 220 1/2"	6
			C-Channel 63"	6
6		L Angle Support	224 3/8"	2

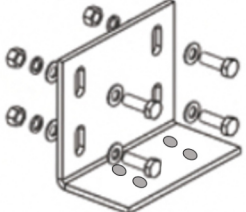
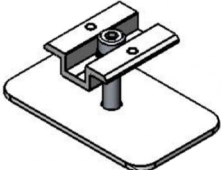
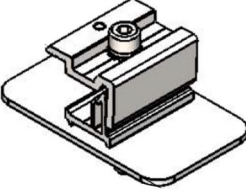
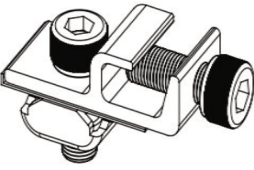
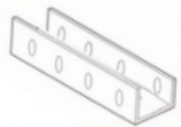
CAT	Picture	Description Part	Details	QTY
7		C Channel Fix Kit CK-PL-GT001-016-14	C Channel Fix Kit	18
			HDG Bolt M10*35	72
			HDG Bolt M16*140	36
			HDG Nut M10	72
			HDG Nut M16	36
			HDG Washer M10	144
			HDG Washer M16	72
			HDG Spring Washer M10	72
			HDG Spring Washer M16	36
8		Mid Clamp Mid Clamp Share Plate	Mid Clamp	60
			Mid Clamp Share Plate	60
			Self Tapping Screw	60
			SS304 Bolt M8*45	60
			SS304 Spring Washer M8	60
9		End Clamp End Clamp Share Plate	End Clamp	24
			End Clamp Share Plate	24
			Self Tapping Screw	24
			SS304 Bolt M8*45	24
			SS304 Spring Washer M8	24
10		Grounding Lug CK-GTC-R2	Grounding lug - weeb lug 8.0	6
			SS304 outer hex bolt 1/4" *0.6"	6
			SS304 inner hex bolt M8*20	6
			SS304 inner hex bolt M8*20	6
11		C Channel Splice	M10*35 Bolts	96
			M10 Flat Washer	96
			M10 Spring Washer	96
			M10 Hexagon Nut	96

INSTALLATION STEPS

1. Build Base

Solution A, Build base

- ✓ Mark footer location according to the diagram. Verify all angles are square (See Attached Planset).
- ✓ Dig footers and make base with anchor bolts according to site conditions and system specifications and based on your structural engineer instructions for foundations requirements.
- ✓ If the ground is unlevel, ensure that all footer placements are level and at the same height regardless of the terrain elevation. Never install the structure tilted, the columns must always be straight.
- ✓ The structure's foundations should be calculated taking into account site conditions, soil type, seismic conditions, maximum wind and snow loads for the site location and the product mechanical loading specifications. In some cases, a geotechnical study is required. Please consult with your local structural engineer.
- ✓ In areas subject to freezing, footer depths may have to increase to resist freeze heave. Always consult a structural engineer to confirm footer depth and dimension.

Solution B, Concrete anchors

- ✓ Concrete anchors can be utilized if approved by a structural engineer.

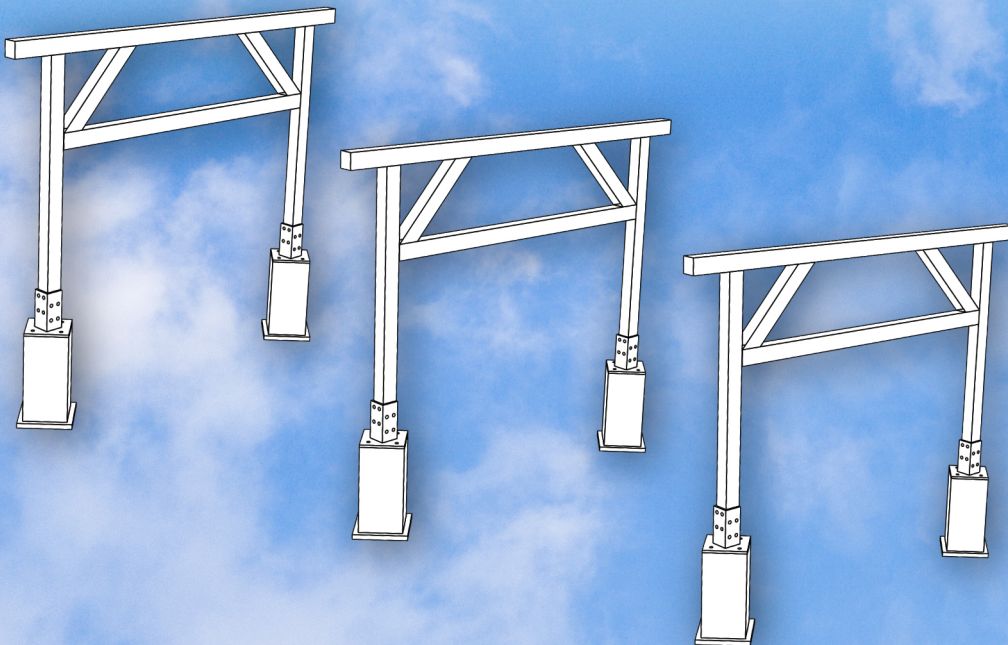

2. Install Base Plates

- ✓ Slide the column base plate over the concrete anchors and secure them. If you are using leveling nuts to level the column base plate. Correct any shifting if needed and repeat for the other three column base plates. Fill the gap between the base plate and the footing with Dry-pack non-shrink grout.
- ✓ Verify the distance between the front and rear column conform with the attached planset.

Products Name	Quantity
Base	6

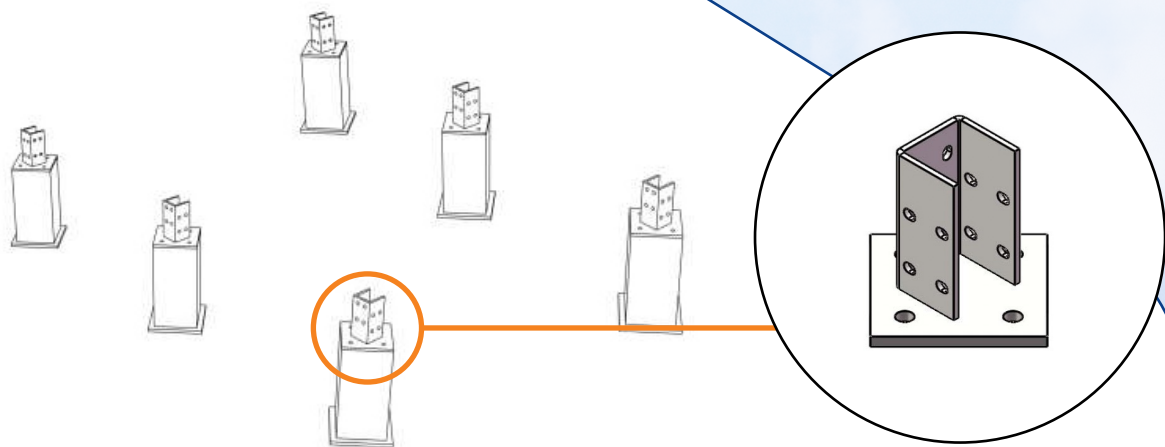

3. Fix Adapter

- ✓ A . Fix Low Beam/Diagonal Brace Adapter to Front & Rear Columns
- ✓ B1. Attach C-Channel Fix Kit to Support Beam
- ✓ B2. Attach Top Column Adapter to Support Beam

Front Column: 111"
 Rear Column: 126 1/2"
 Low Beam/Diagonal Brace Adapter: 16 1/2"
 Top Column Adapter: 10 3/16"
 Support Beams: 228 5/16"

Products Name	Quantity
Top Column Adapter	6
M16*140mm Bolt Kits (1 big flat washer + 1spring washer + 1 nut)	36
Lower Horizontal Beam/Diagonal Brace Adapter	6
C-Channel Fix Kit	18

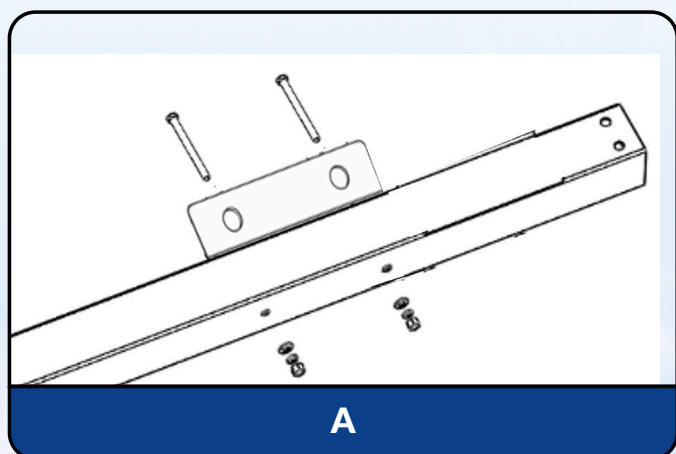

A

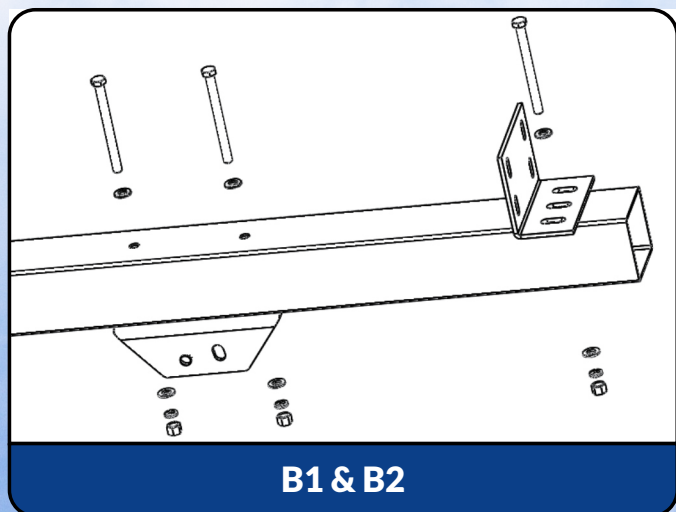
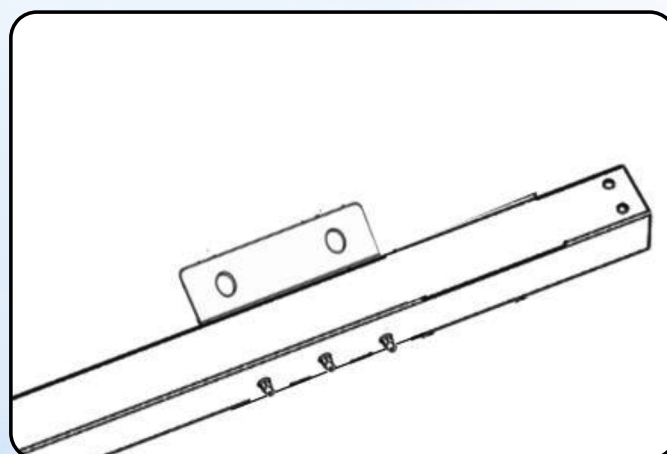

B1 & B2

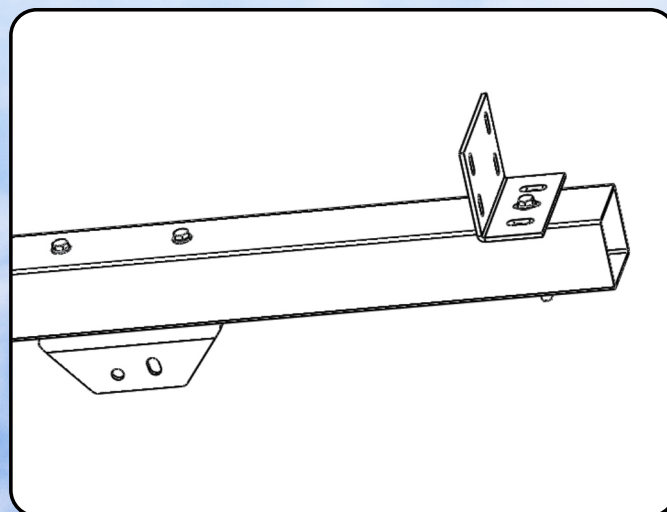

4. Connect Columns

✓ Attach Columns to base plate

Products Name	Quantity
Front Columns --- 111"	3
Rear Columns --- 126 ½"	3
M16 *180mm Bolt Kits (1 flat washer + 1 spring washer + 1 nut)	24

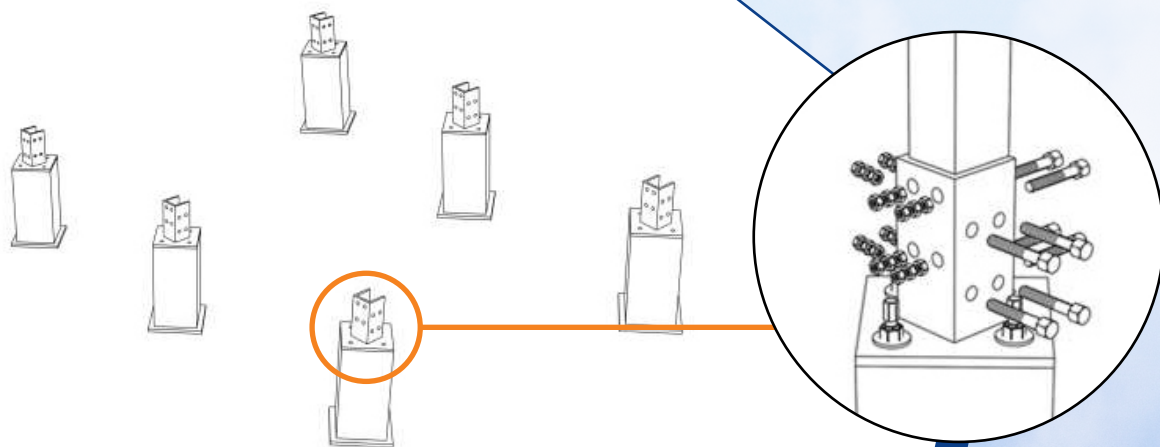

5. Connect Beams

- ✓ Connect Lower Horizontal Beam to front and rear Columns
- ✓ Connect Support Beam between front and rear columns on top
- ✓ Connect Diagonal Brace between Support Beam and Column

Products Name	Quantity
Lower Horizontal Beam 168 ¹ / ₁₆ "	3
Top Support Beam 228 ⁵ / ₁₆ "	3
Diagonal Brace 47 ³ / ₁₆ "	6

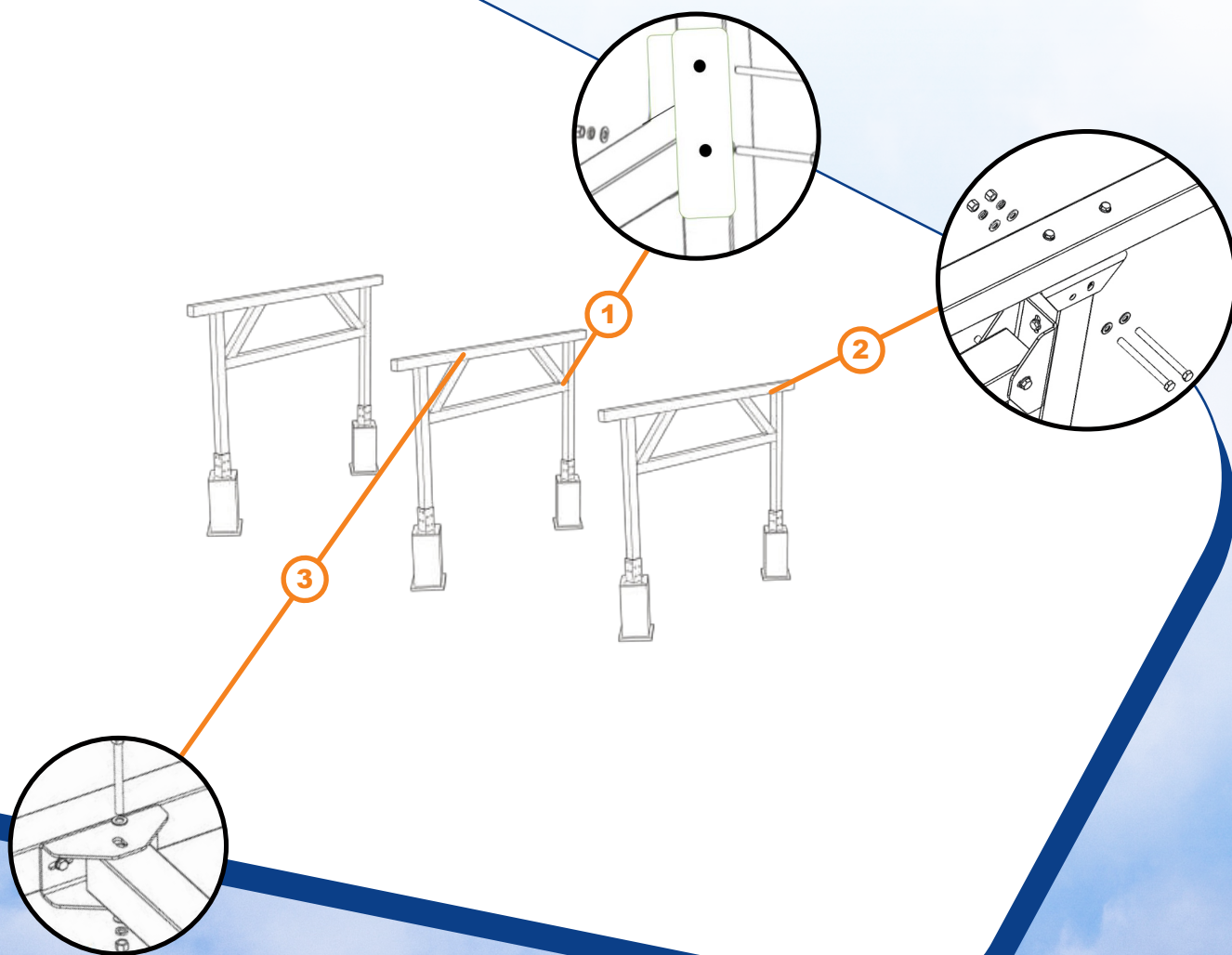

6. Fix C Channel

- ✓ Combine C-Channels with C-Channel Splice Kits
- ✓ Use C-Channel Fix Kit to connect C-channels to Top Support Beam
- ✓ Use M10*16mm Bolt Kits (1 flat washer + 1 Spring Washer + 1 Nut)
- ✓ Use M10*25mm Bolt Kits (1 flat washer + 1 Spring Washer + 1 Nut)

Products Name	Quantity
C Channel --- 220 1/2"	6
C Channel --- 63"	6
C-Channel Fix Kit	18
C-Channel Splice Kit	12
M10 180mm Bolt Kits (1 flat washer + 1 spring washer + 1 nut)	120
M16 180mm Bolt Kits (1 flat washer + 1 spring washer + 1 nut)	120

*When spliced, total length of C-Channels is 283 1/2"

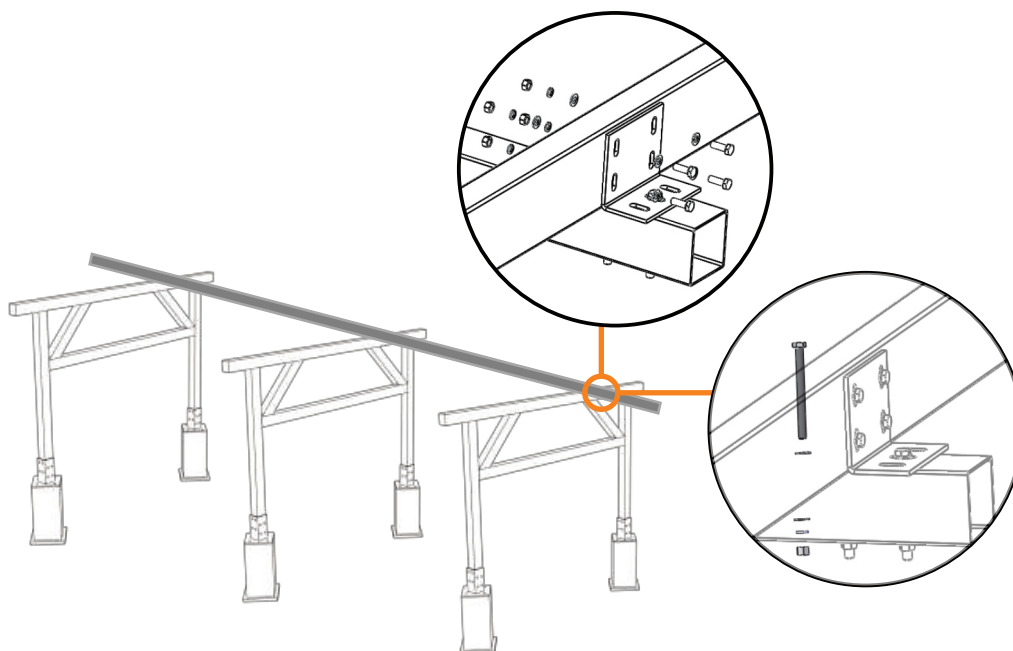

7. U-Rail Construction

1. Connect 2 U-Rails using the U-Rail Splice. The U-Rail will have pre-drilled holes at the ends of the U Rails where the splice connects using Hex Bolt M10*30 Once the U-Rails are connected the rail count will be 13qty. The U-Rail will also have 6 existing holes that will line up with the top of the C-Channels.

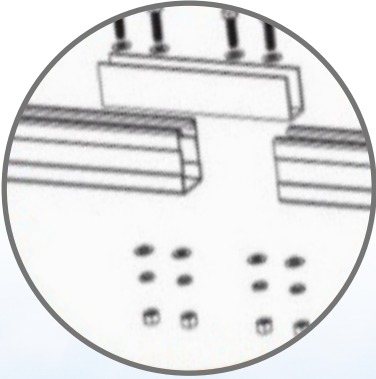

Products Name	Quantity
U-Rails 137 ³ / ₄ "	14
U-Rail Splice Kits	7
Mid Clamps	60
End Clamps	24
M10*30 Bolt Kits	72

U-Rail Configuration

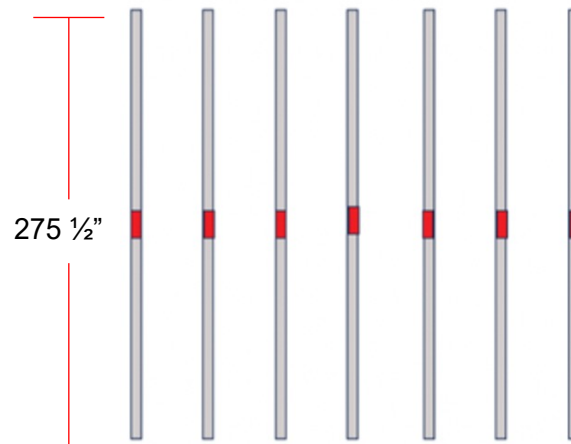

■ = Splice Location

8. Fix U Rail

1. Determine your 1st U-Rail attachment location on top of the C-Channels by utilizing the attached Math Module Placement Guide (you can start at either end) Your module width will determine your U-Rail attachment location. Once you determine the starting point for the 1st U-Rail ensure the starting distance is equal on the top C-Channel And the bottom C-Channel. You can mark all holes and drill C-Channel connection points.
2. Once your 1st U-Rail is secure, place end clamps into this U-rail.
3. Place a second U-rail on top of the C-channels with Mid-Clamps installed. Do not secure 2nd U-rail to C-channels until you verify the mounting distance between U-Rails is correct. Verify mounting distance Between U-Rails by mounting one module and ensuring proper spacing between of U-rails. The module should fit tight and should be square. Once verified attach 2nd U-Rail to C-channels using 6 Hex Bolts M10*30.
4. Install the remaining 11 U-rails connected and spliced U-Rails on top of C-Channels using 6 Hex Bolts M10*30 for each U-Rail.
5. If waterproofing, with U-Rail Gasket, do NOT install panels until waterproofing is complete.
6. Place all modules on top of carport tightening end and mid clamps to provided torque specs.

Please Review Math Calculation in Appendix

Products Name	Quantity
U Rails 137 ³ / ₄ "	14
M10*30	72

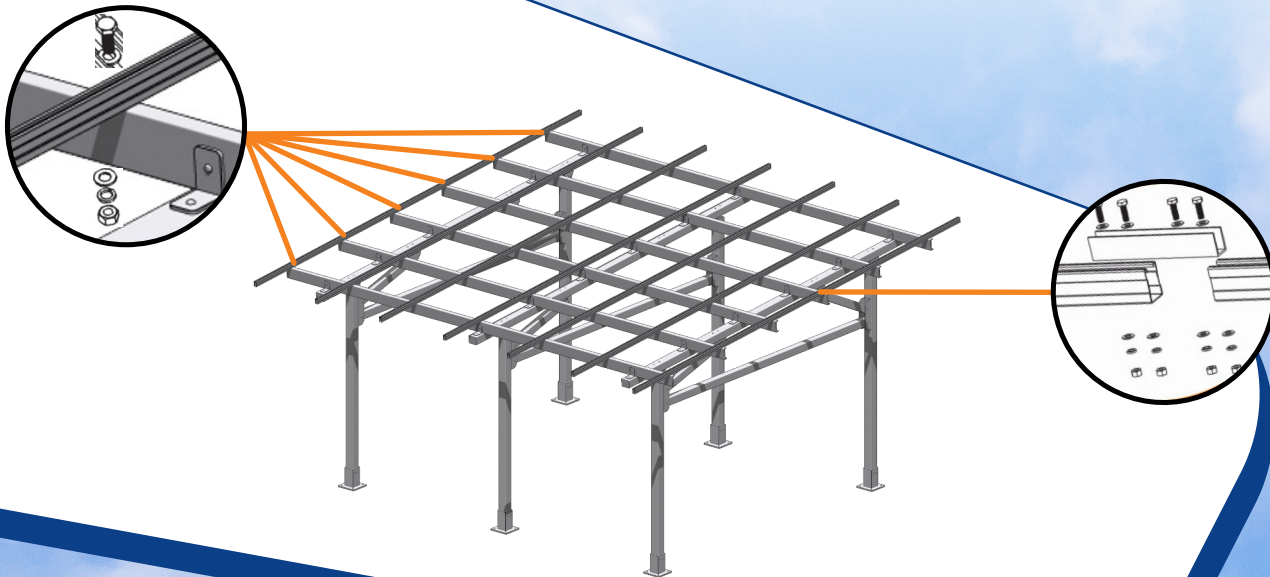

9. Install L-Angle Supports

L-Angle supports provide continuous stability and reduce any twisting or settling that may occur within the C-channel system. The L-Angle supports are attached to the bottom-center of the C-Channels using M8 screws. Each L-angle support will be attached with 6-qty M8 screws at 6 separate contact points on six separate C channels. The L-Angle support will run Perpendicular to the C-Channels and parallel to the Top Support Beam. The L-Angle supports will be installed in the center of each car bay (See Diagram Below).

Products Name	Quantity
L-Angle Support 224 ¹ / ₁₆ "	2
M8 Screws	12

L-Angle Support Installation Locations

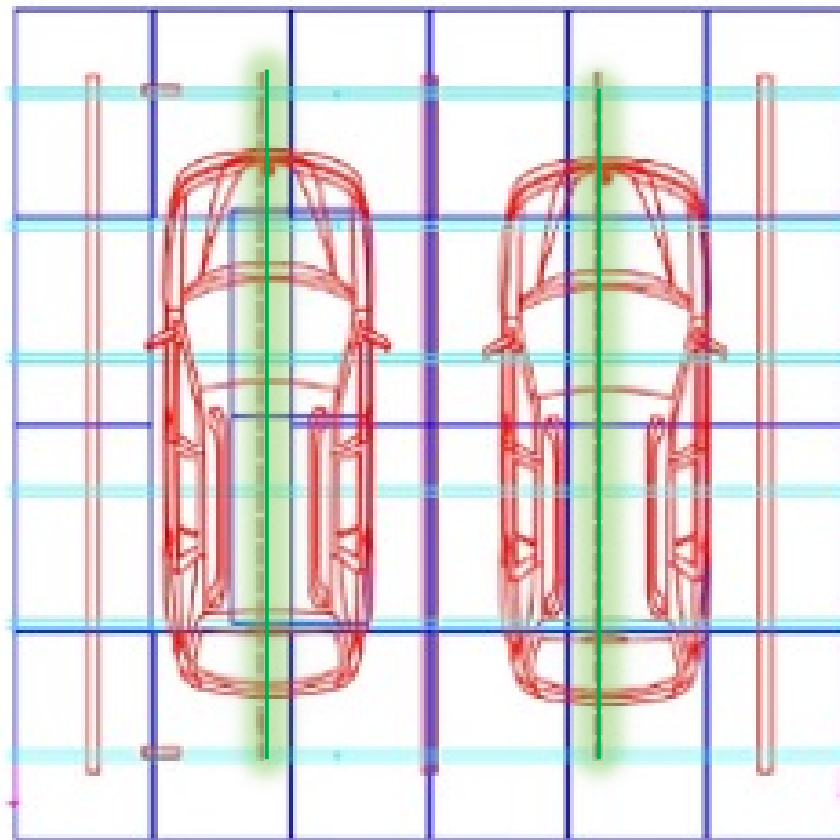

— = L-Angle Support

10. Install Solar Panels

- ✓ For waterproofing stick rubber molding to exterior of module frame but only where the frames are adjacent to other module frames or on all interior seams
- ✓ Install U-Rail waterproofing gasket by pressing gasket down onto the top channel of U-rail. The gasket has been designed to snap into place inside the top of the U-Rail. Try to size the pieces so no gap spacing occurs.

Products Name	Quantity
Modules	18 or 24
Rubber Molding	1 Roll
U-Rail Gasket	1 Roll

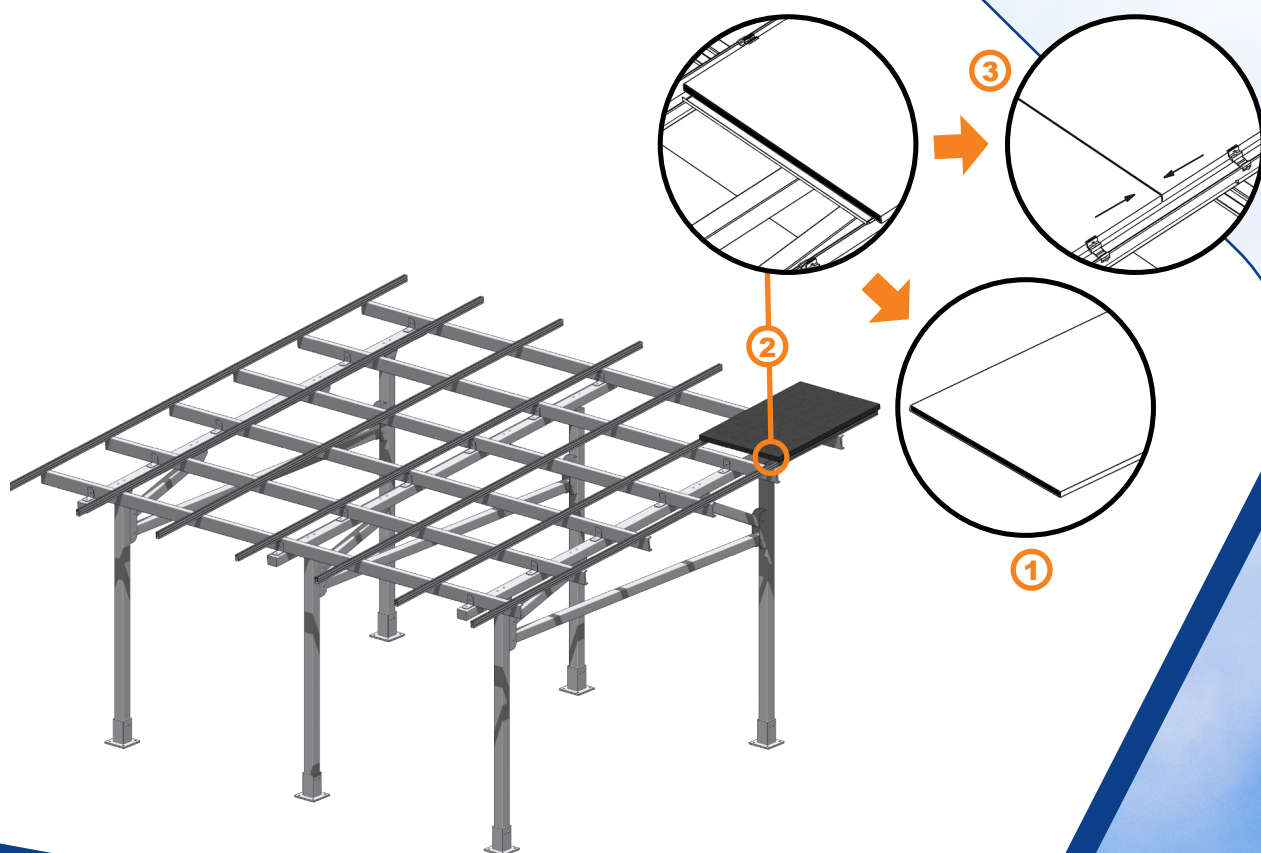

11. Grounding- Lug and Wiring

Install grounding lug at end of C-Channel on side of array that is most optimal for wire management. Ensure that all paint and any debris is removed from bonding site to achieve proper bonding connection. Attach each ground lug with a stainless steel nut then cross 8.4mm² or greater than or equal to 8AWG copper wire through all 6 grounding lugs (fixed by M8*20 inner hex bolt), finally connect copper wire to the ground. The grounding lug completes a grounding function when fastened tight to connect all 6 C-Channels and copper wire.

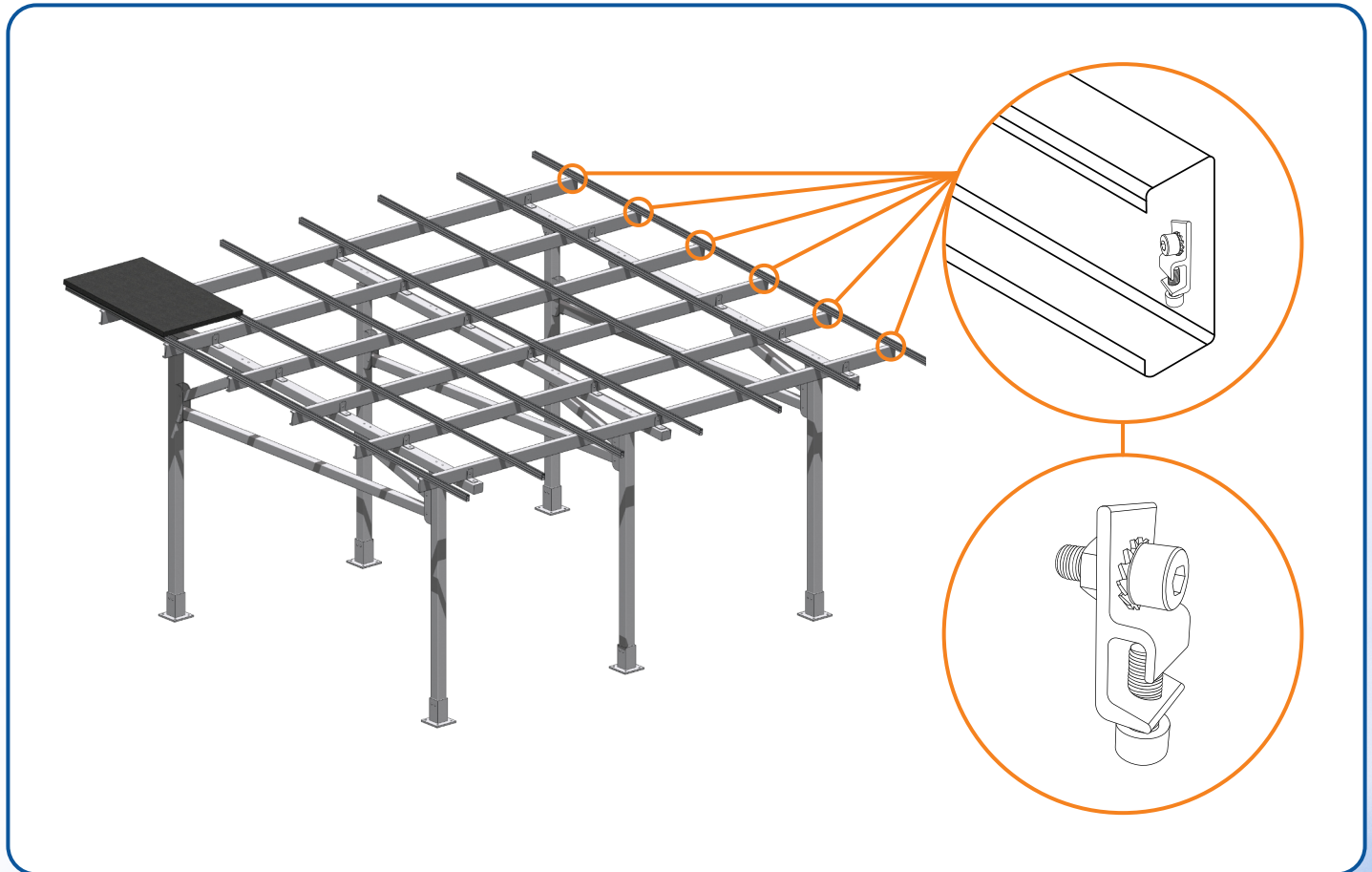

Electrical Characteristics of AWG Copper Wire

AWG	Diameter [inches]	Diameter [mm]	Resistance [Ohm / 1000ft.]	Resistance [Ohm / km]	Max Current [Amperes]	Max Frequency for 100% skin depth
6	0.162	4.1148	0.3951	1.295928	37	1100 Hz
7	0.1443	3.66522	0.4982	1.634096	30	1300 Hz
8	0.1285	3.2639	0.6282	2.060496	24	1650 Hz
9	0.1144	2.90576	0.7921	2.598088	19	2050 Hz
10	0.1019	2.58826	0.9989	3.276392	15	2600 Hz

Grounding - Lug and Wiring Diagram

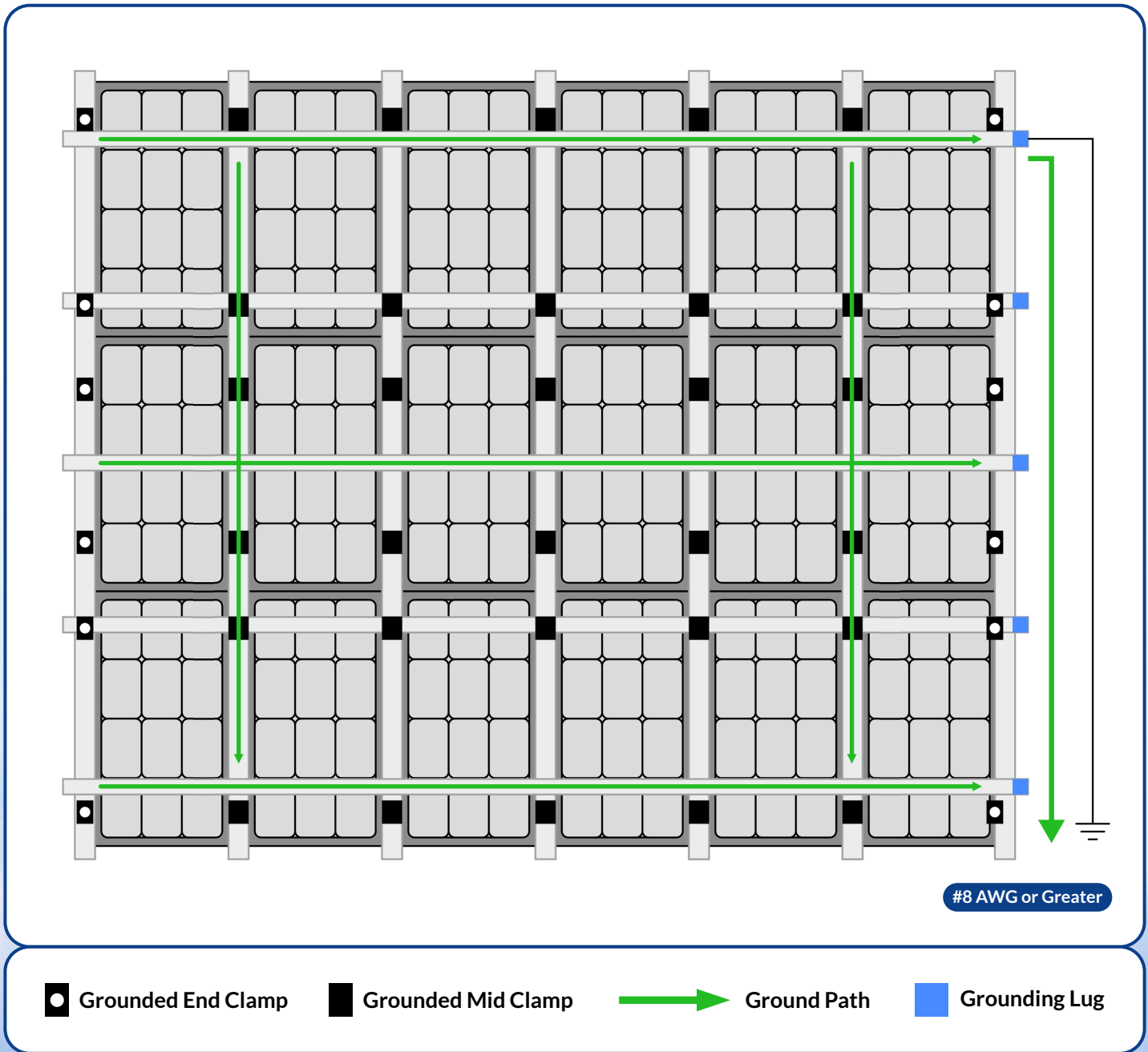

12. Final Check

- ✓ Check and verify that all components are properly fastened and installed properly in their correct positions and locations.
- ✓ Verify and re-adjust all components as needed within the structure.

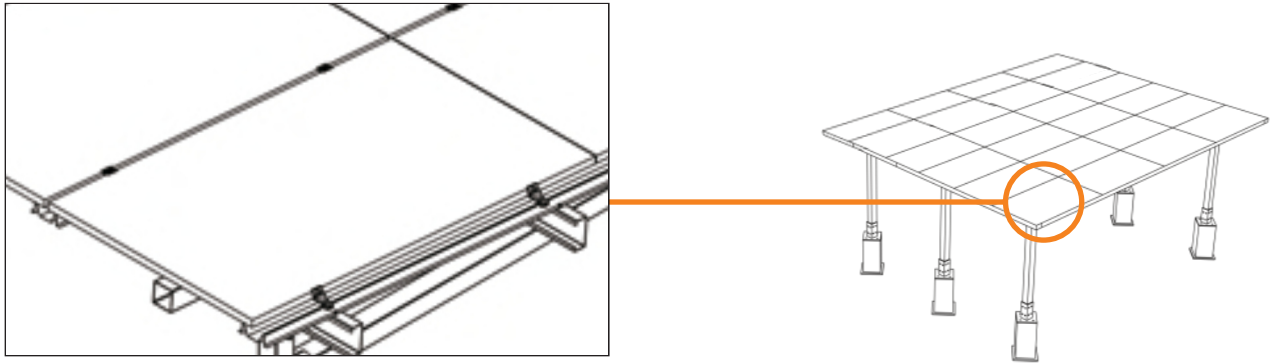

12. Hide Footing (Optional)

- ✓ Cladding of 4 bases is an option with engineer approval.

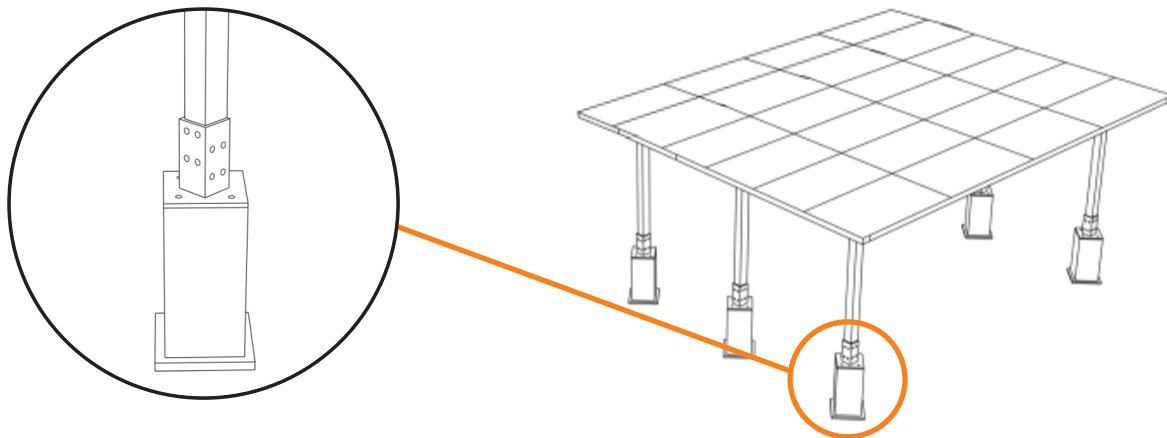

WORLDLEADING

M A N U F A C T U R E



CHIKOUSA
RACKING MADE SIMPLE

Tel : 1-800-948-5390

Email : info@chikousa.com

www.chikousa.com



101 East Baseline Road
Buckeye, AZ 85326

MAXIMO 185 TWO CAR CARPORT

Panel Layout : 4x6

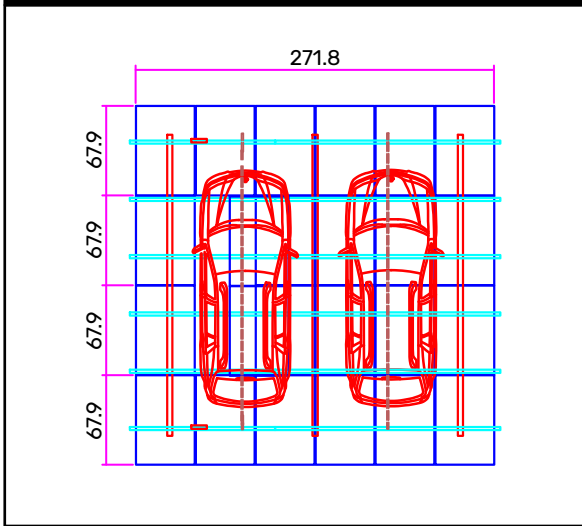

C Channel Layout

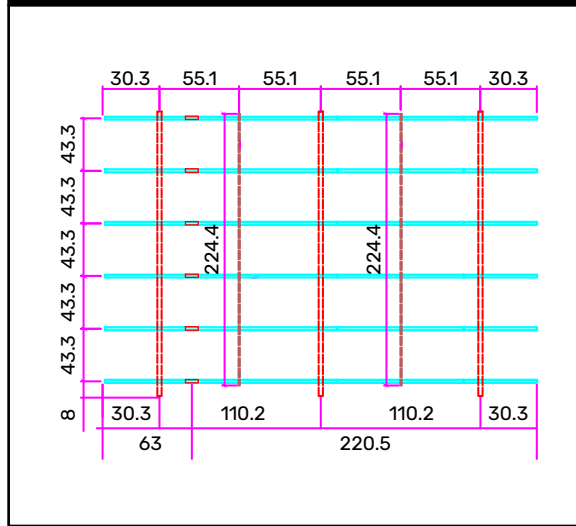

C Channel & U Rail Layout

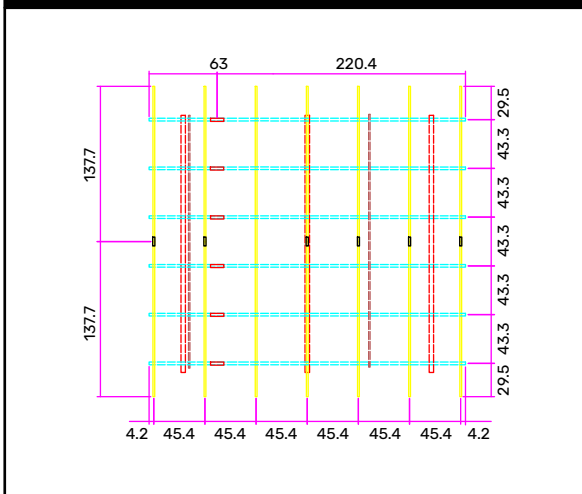

Foundation Layout

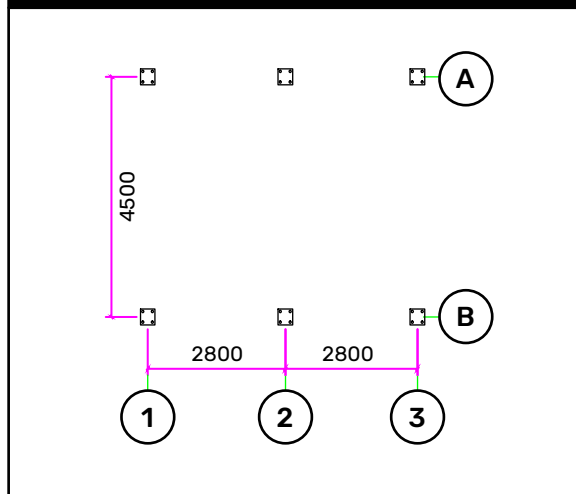

Layout : 4x6

BOM

NO	DESCRIPTION	QTY
1	Support Rack	3
2	End Clamp	24
3	End Clamp share plate	24
4	Mid Clamp	60
5	Mid Clamp share plate	60
6	C Rail fix kit	30
7	C-Channel 220 1/2"	6
8	C-Channel 63"	6
10	C-Channel Splice	6
11	U-Rail 137 3/4"	14
12	U-Rail Splice	7

Design Factors :
 Module Dimensions : 1724*1134*34
 Tilt Angle : 5°
 Front Clearance : 111
 Wind Speed : --
 Snow Load : --

Modify by	Doc No.	Data	Des	J. Burton	241105
			Drw		
			Check		
			Craft		
			App		

CHIKOUSA

Maximo 185

Maximo185 2-Car

4x6-5°

View :

Rate

Page /

MAXIMO 185 TWO CAR CARPORT C-CHANNEL SPLICE LOCATIONS

 = SPLICE

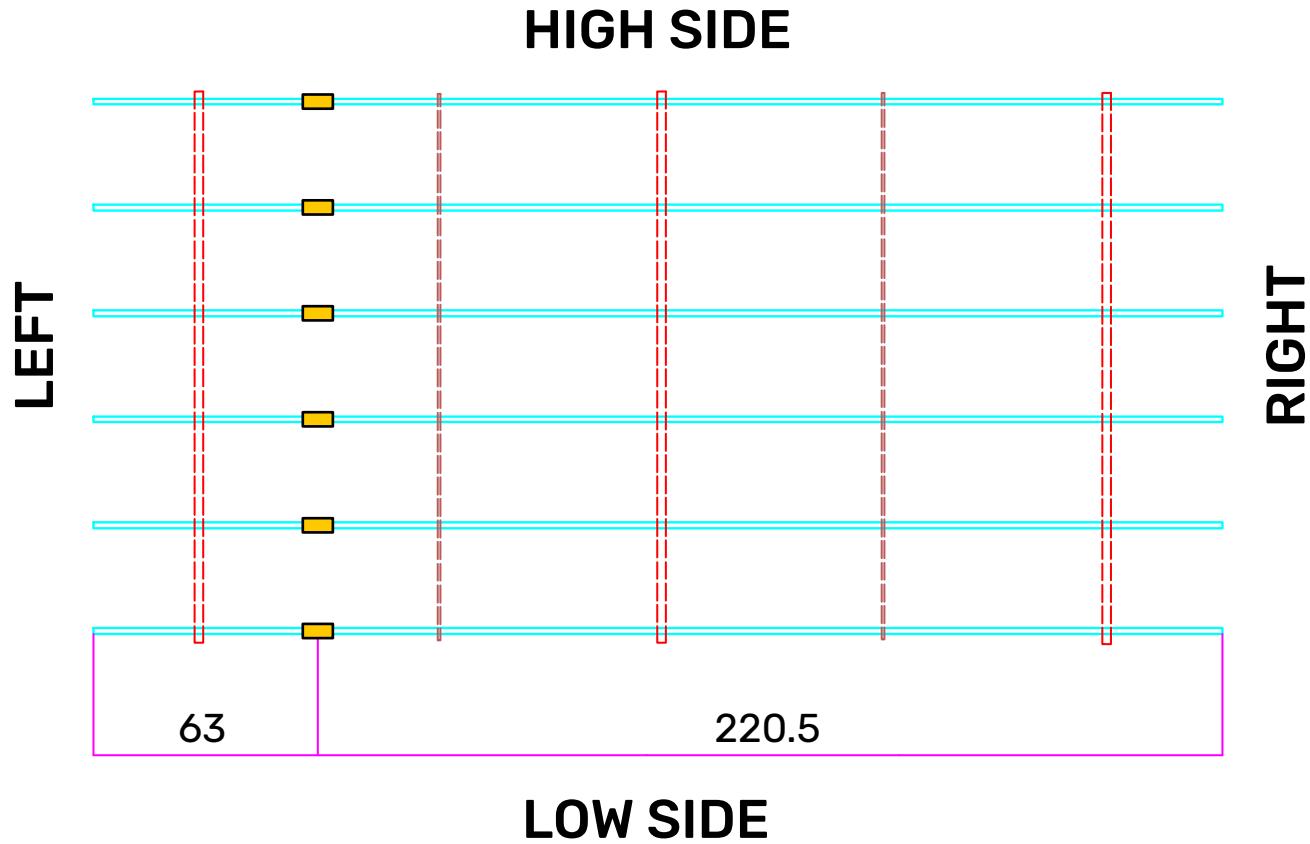

	Modify by	Doc No.	Data	Des	J. Burton	241105
				Drw		
				Check		
				Craft		
				App		

CHIKOUSA		
Maximo185 2-Car		
Splice Locations		
View : 	Rate	Page /

4

4

3

3

2

2

1

1

A

B

C

D

MAXIMO 185 TWO CAR CARPORT FOUNDATION LAYOUT

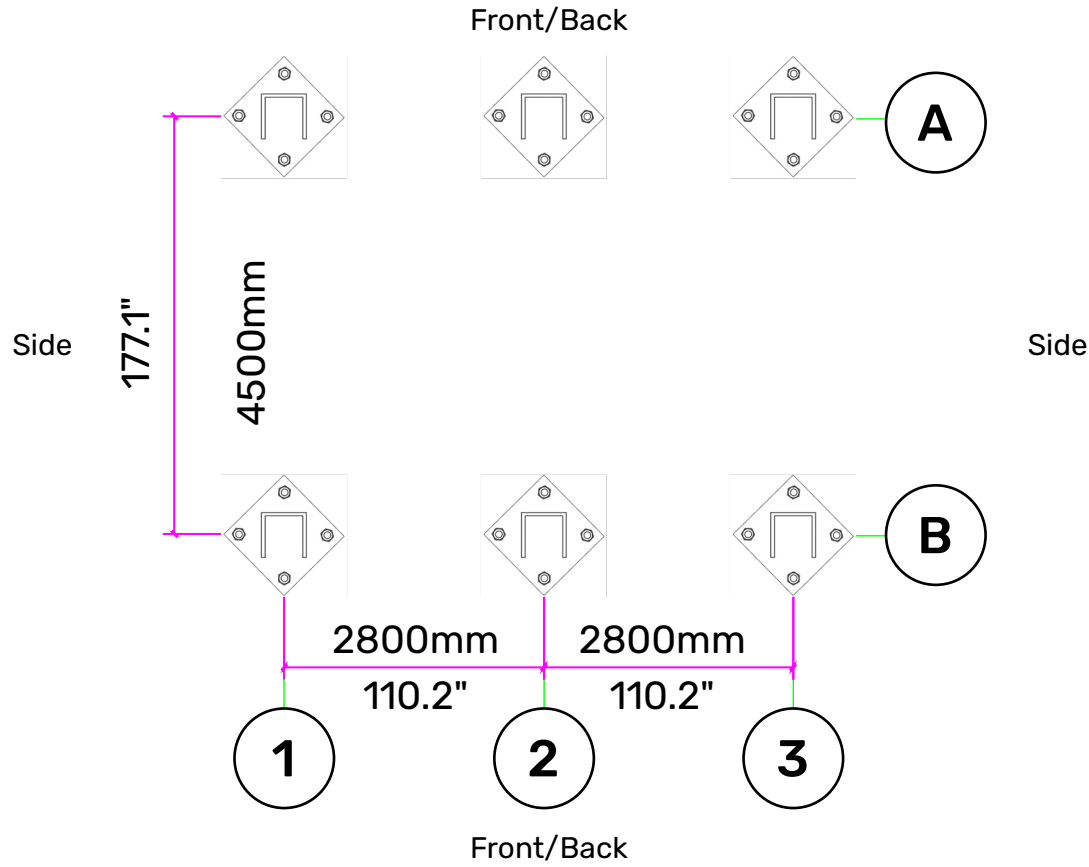

Note: Base Plates shown can rotate 180° based on aesthetic preference.
The C opening can either face down (image shown) or up. The C-opening cannot face to either side

	Modify by	Doc No.	Data	Des	J. Burton	241105	CHIKOUSA	
				Drw			Maximo185 2-Car Foundation	
				Check				
				Craft			View :	Rate
				App			Page /	

CHIKO CARPORT BASE PLATE DRAWING - IN MM

270MM X 270MM

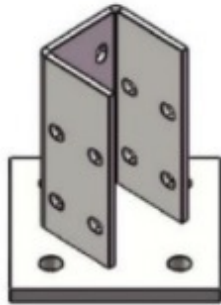

4- \dot{y} 18*25
penetration

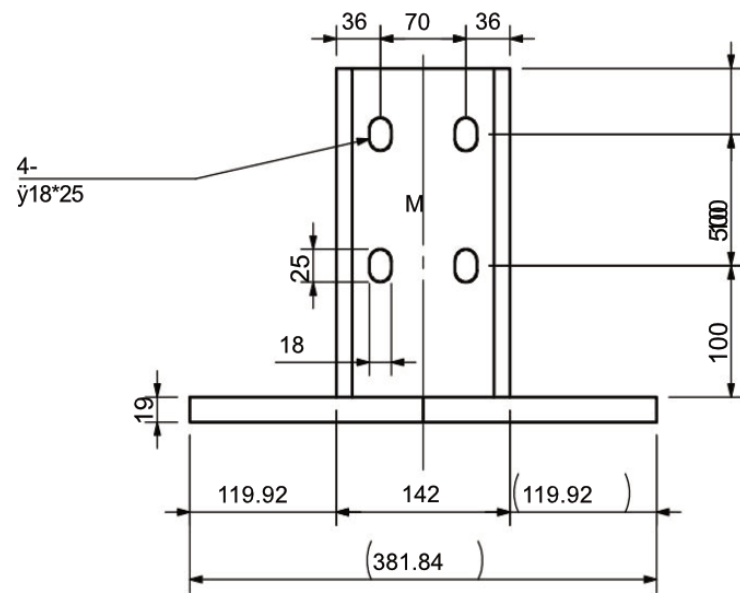
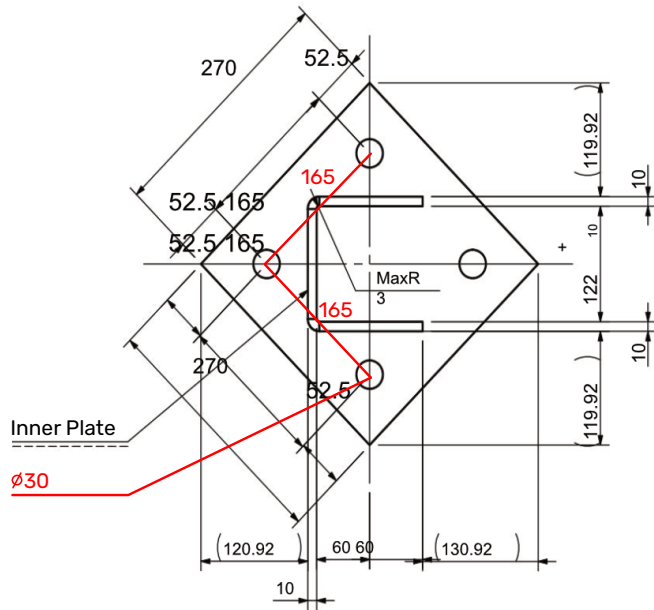
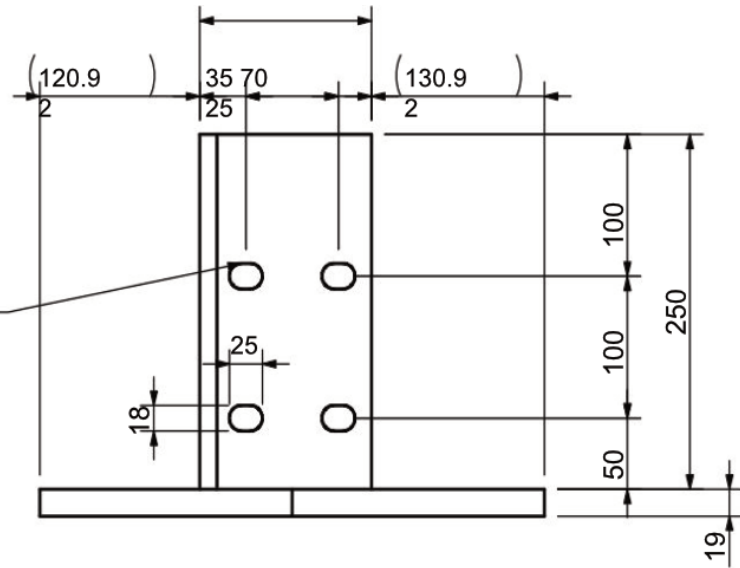

		Modify by	Doc No.	Data	Des	J. Burton	241105	CHIKOUSA		
					Drw					Maximo185 2-Car
					Check			Base Plate		
					Craft			View :	Rate	Page /
					App					

CHIKOUSA Carport Base Plate

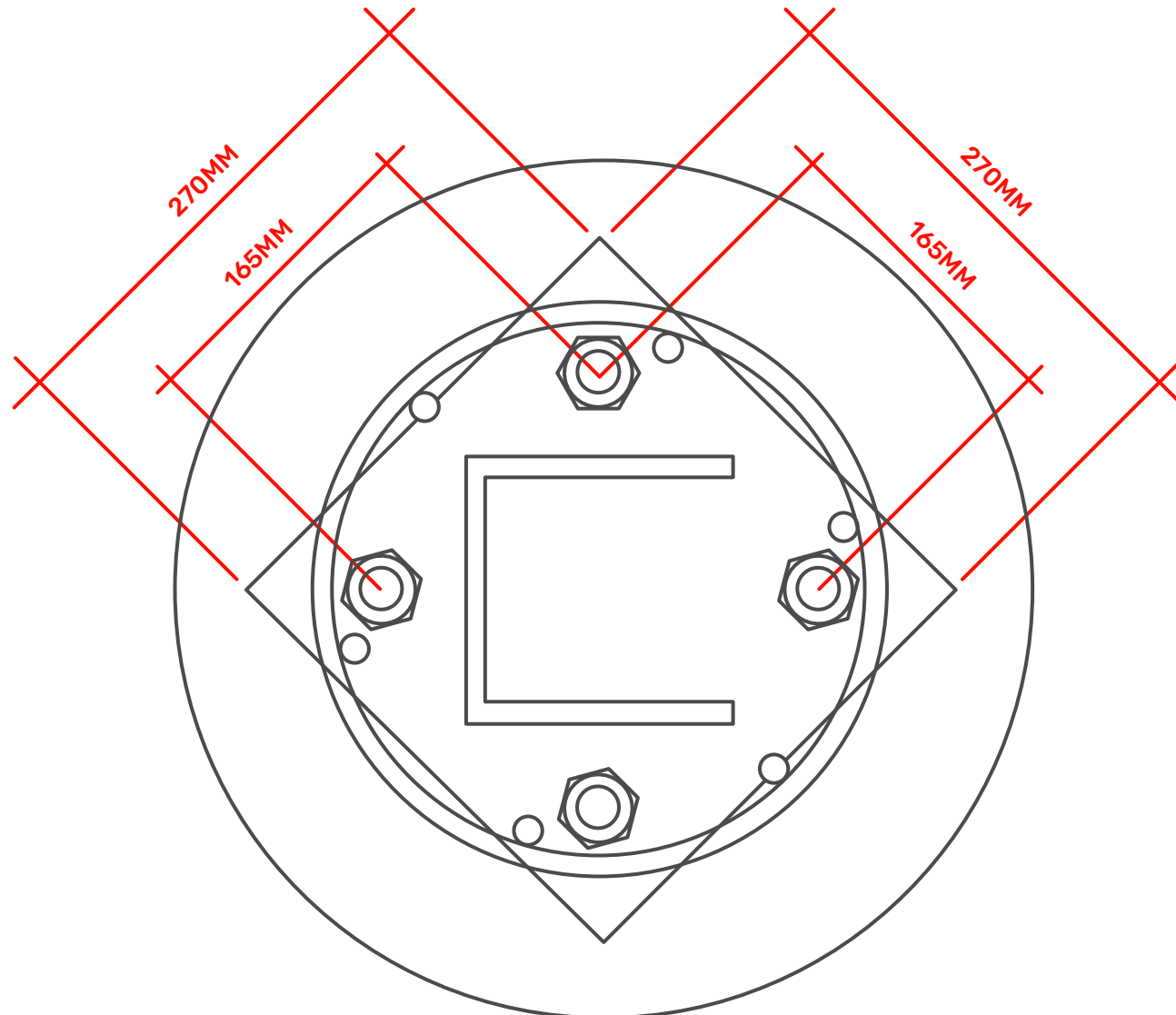

Bottom Holes M-30

Note: Base Plate Will Be Installed At 90 Degree Angle to the Structure

SIDE PROFILE AND PARTS DIAGRAMS

(Please note: the open side of the C-Channel faces the high side of the Carport)

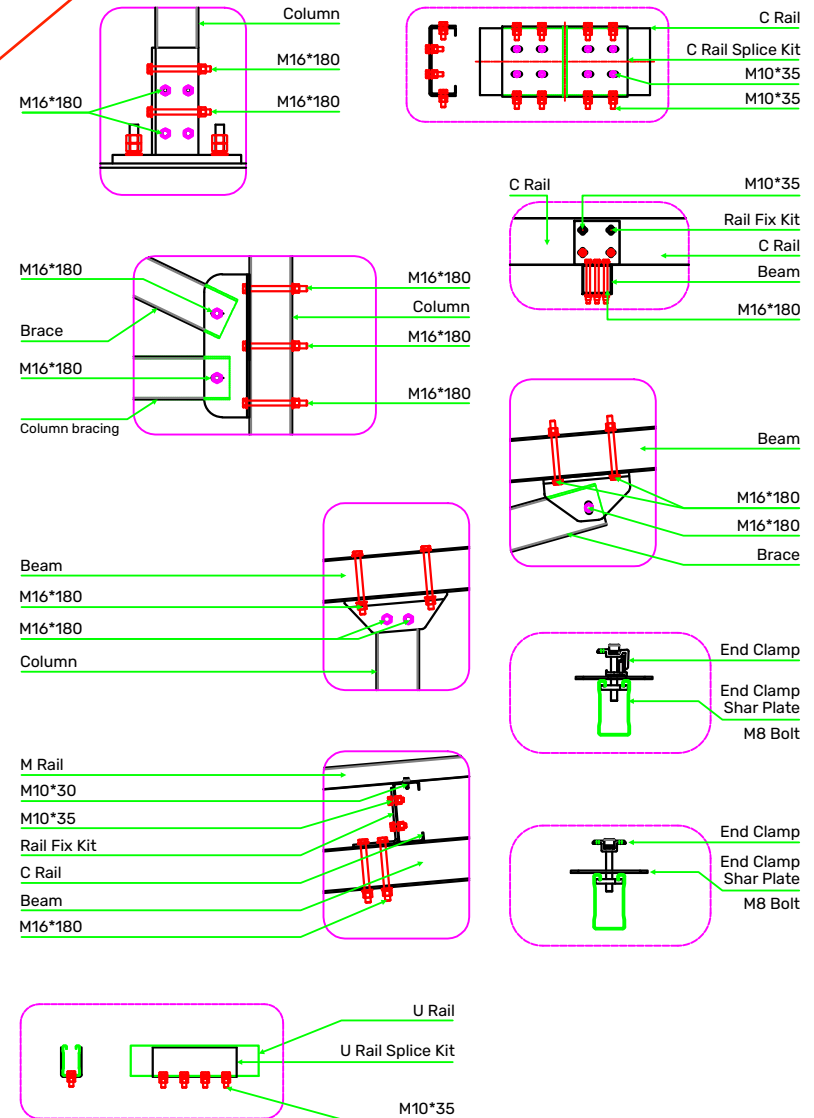
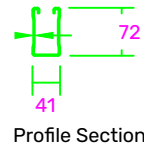
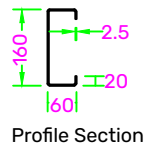
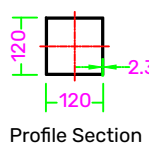
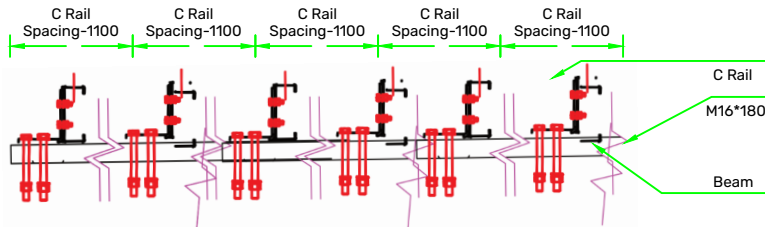
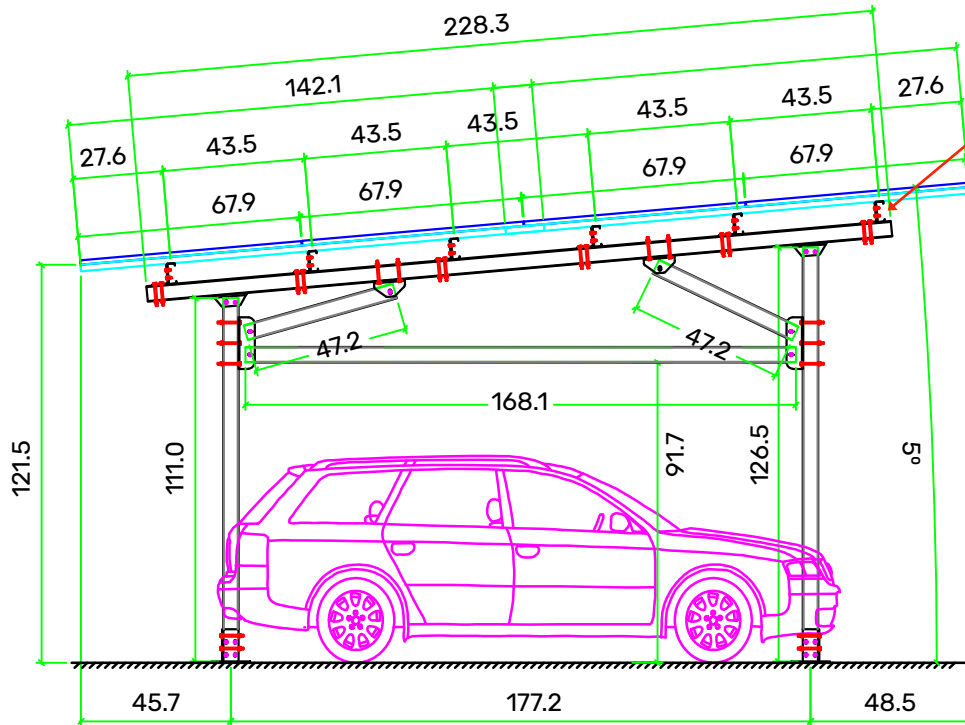

Design Factors :
 Module Dimensions : 67.9 x 44.6
 Tilt Angle : 5°
 Front Clearance : 111
 Wind Speed : --
 Snow Load : --

Modify by	Doc No.	Data	Des	J. Burton	241105
			Drw		
			Check		
			Craft		
			App		

CHIKOUSA

Maximo185 2Car
Side Profile + Parts

View :

Rate Page /