

emporía

Don't
have enough
power / amps?
We can help!
Contact
us!

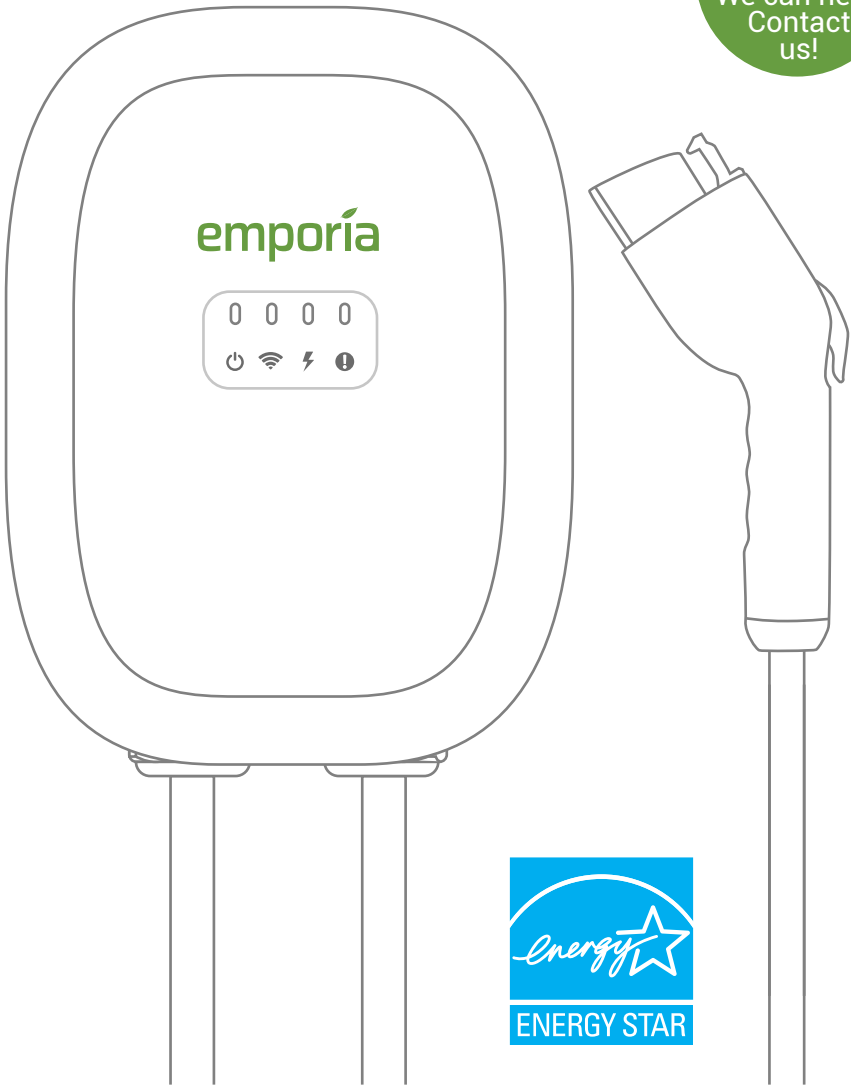

Smart Home EV Charger

Installation and Usage Guide



Numérisez le code QR pour le guide d'installation et d'utilisation dans d'autres langues

Escanee aquí para obtener la Guía de instalación y uso en otros idiomas



IMPORTANT SAFETY INSTRUCTIONS

SAVE THESE INSTRUCTIONS

INSTRUCTIONS PERTAINING TO A RISK OF FIRE OR ELECTRIC SHOCK!

Improper connection of the equipment-grounding conductor may result in a risk of electric shock, leading to death or serious injury. Emporia recommends that installation be performed by a licensed electrician or other qualified professional in accordance with the regional electrical code where it is being installed to ensure the Emporia EV Charger is properly grounded. Do not modify the provided plug – if it will not fit the outlet, have a proper outlet installed by a licensed electrician or other qualified professional.

GROUNDING INSTRUCTIONS

For Plugged-In Installation:

This product must be grounded. If it should malfunction or break down, grounding provides a path of least resistance for electric current to reduce the risk of electric shock. This product is equipped with a cord having an equipment grounding conductor and a grounding plug. The plug must be plugged into an appropriate outlet that is properly installed and grounded in accordance with all local codes and ordinances.

WARNING - Improper connection of the equipment-grounding conductor is able to result in a risk of electric shock. Check with a qualified electrician or serviceman if you are in doubt as to whether the product is properly grounded. Do not modify the plug provided with the product - if it will not fit the outlet, have a proper outlet installed by a qualified electrician.

For Hardwired Installation:

This product must be connected to a grounded, metal, permanent wiring system, or an equipment-grounding conductor must be run with the circuit conductors and connected to the equipment grounding terminal or lead on the product.

Important safety instructions

SAVE THESE INSTRUCTIONS

WARNING

INSTRUCTIONS PERTAINING TO A RISK OF FIRE OR ELECTRIC SHOCK

- Read all the instructions before using this product.
- This device should be supervised when used around children.
- Do not put fingers into the electric vehicle or charger connectors.
- The EV Charger is intended for use with electric vehicles only. Specifically, it is intended only for electric vehicles not requiring ventilation during charging.
- The EV Charger is intended to be installed in stationary, grid-tied power systems. Do not use the EV Charger with back-up generators.
- Do not use the EV Charger in any manner other than specified in this installation guide.
- Do not attempt to disassemble or repair any of the components of the EV Charger. There are no user serviceable parts inside.
- Do not use this product if the flexible power cord or charging cable is frayed, has broken insulation, or any other signs of damage.
- Do not use this product if the enclosure or the connector is broken, cracked, open, or shows any other indication of damage.
- Do not install the EV Charger in environments with explosive gas or vapors; nor where temperatures are outside its operating range of -22°F to 122°F (-30°C to 50°C).
- Use 194°F (90°C) wire, 6 AWG copper when installing a 48A connection in a hardwire installation.

Moving and storage instructions

- Improper moving or storage of the EV Charger may result in damage to the product that could result in a risk of fire or electric shock during subsequent use.
- Handle charger and packaging with care and avoid dropping it. When moving or lifting the EV Charger, always grasp the unit by the charging station enclosure. Never carry or lift the EV Charger by either the power cable or charging cord.
- Store the EV Charger indoors and in its original packaging until it is ready to be installed. Storage temperature should be between -22°F to 122°F (-30°C to 50°C).
- Always place protective cover on the J1772 EV Charger connector when not in use. The NACS connector does not have a cover.
- Modifying the EV Charger in any way not outlined in this installation guide, including drilling holes in the charger, will void the manufacturer warranty.

Need help?

- 🗨 emporiaenergy.com/support
- ✉ support@emporiaenergy.com
- ☎ 1-844-EMPORIA (367-6742)

What's in the box

Your new Emporia EV Charger contains the following items. **If any of these items are missing or if you believe they've been damaged, call support immediately.**

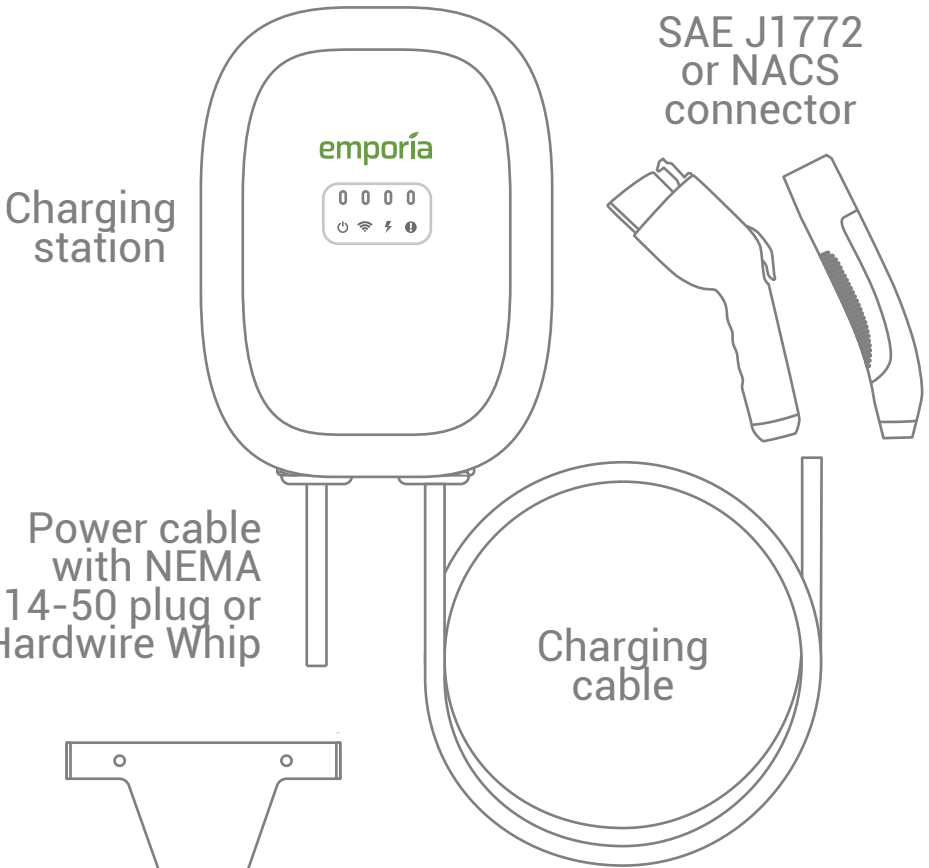

Charging station

SAE J1772 or NACS connector

Power cable with NEMA 14-50 plug or Hardwire Whip

Charging cable

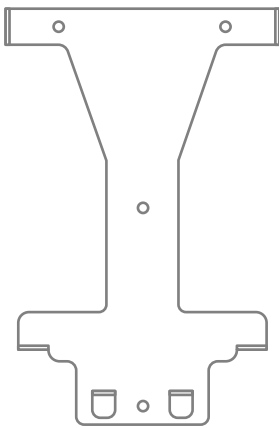

Mounting bracket



Four M5X10 Phillips screws

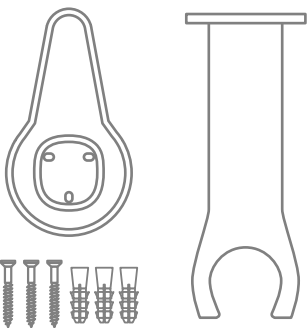

Charger may come with plastic or metal connector cradle (See Step 5a or 5b)

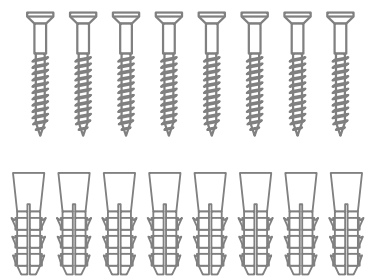

Eight 7/32 inch #12 Phillips screws and drywall anchors

Before you get started

Here are the tools you will need to install the Emporia EV Charger:

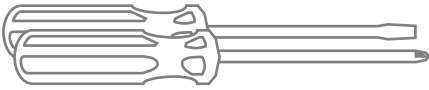

Phillips and flathead screwdrivers



Bubble level



Pencil



Hammer



iOS or Android phone or tablet

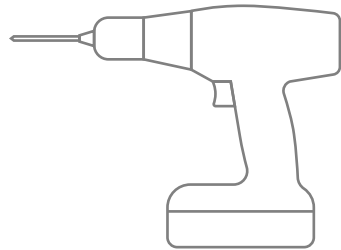

Drill with 5/16" (8mm) and 1/4" (6mm) drill bits

Need help?

-  emporiaenergy.com/support
-  support@emporiaenergy.com
-  1-844-EMPORIA (367-6742)

Step 1: Get the app and check Wi-Fi

The Emporia EV Charger is capable of charge a vehicle at 40A on a 50A breaker (NEMA 14-50) or 48A on a 60A+ breaker (hardwired). The Emporia Energy app and a Wi-Fi connection are required to take advantage of its smart functions, including: changing the charging rate, integrating with Emporia products and other smart devices, and energy management features.

Download the **Emporia Energy app** onto your phone or tablet from the Apple App Store, from Google Play, or from emporiaenergy.com/app. **Create an account and begin the setup process.**

You can also use your phone to check the signal strength of your Wi-Fi network where the EV Charger will be installed. Low/no signal may require a Wi-Fi extender for the smart features to work.



emporiaenergy.com/app

Step 2: Find a place for the EV Charger

The bottom of the charging station should be wall-mounted at least 24" (610 mm) above the floor or grade. Ensure that there is sufficient slack in the charging cable to reach the vehicle charging port, as well as sufficient slack in the NEMA power cable to reach the outlet (if using the NEMA 14-50 version). The charging station should be installed where temperatures remain between -22°F to 122°F (-30°C to 50°C).

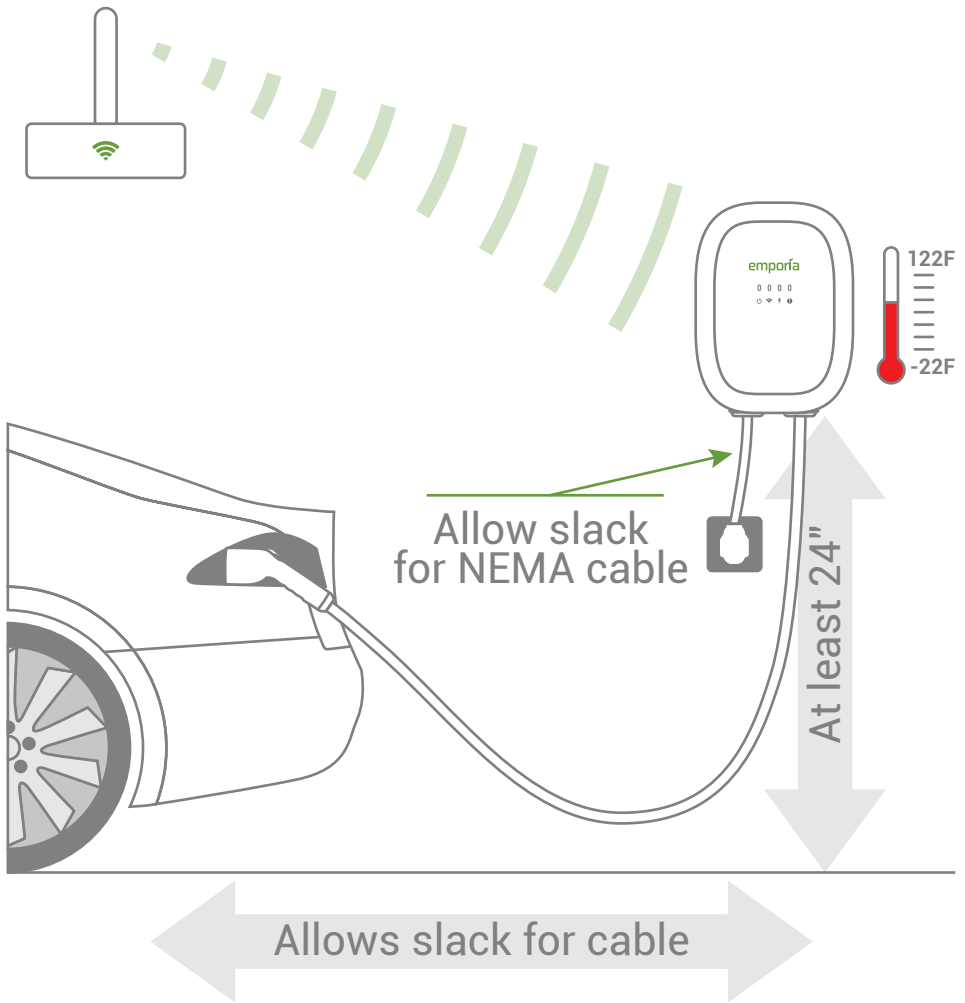

Need help?

- emporiaenergy.com/support
- support@emporiaenergy.com
- 1-844-EMPORIA (367-6742)

Step 3: Mark the mounting bracket location

On the wall where the charging station will be installed, use a bubble level to draw a horizontal line where the top of the charging station will sit on the wall ensuring it is mounted at a sufficient height at least 24" (610 mm) above the floor or grade and allows slack for the NEMA cable if it will be plugged in. Then, align the top of the mounting bracket to the line and mark the 4 mounting holes.

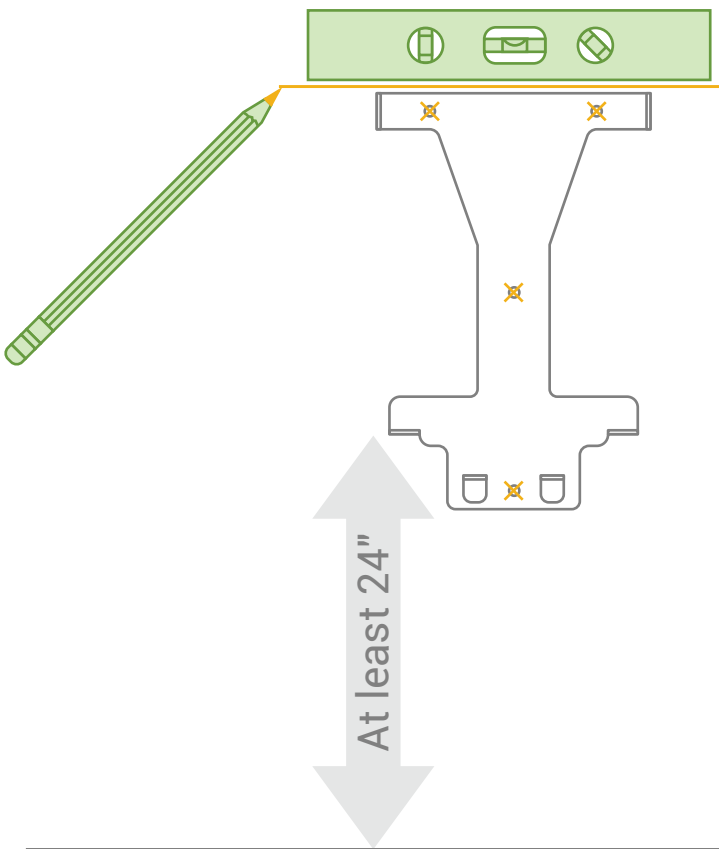

Need help?

- 🗨 emporiaenergy.com/support
- ✉ support@emporiaenergy.com
- ☎ 1-844-EMPORIA (367-6742)

Step 4: Install the mounting bracket

For each mark, drill a 5/16" (8mm) hole in the wall. Use a hammer to tap in the 4 drywall anchors. Install the mounting bracket with the 4 Phillips screws into the anchors.

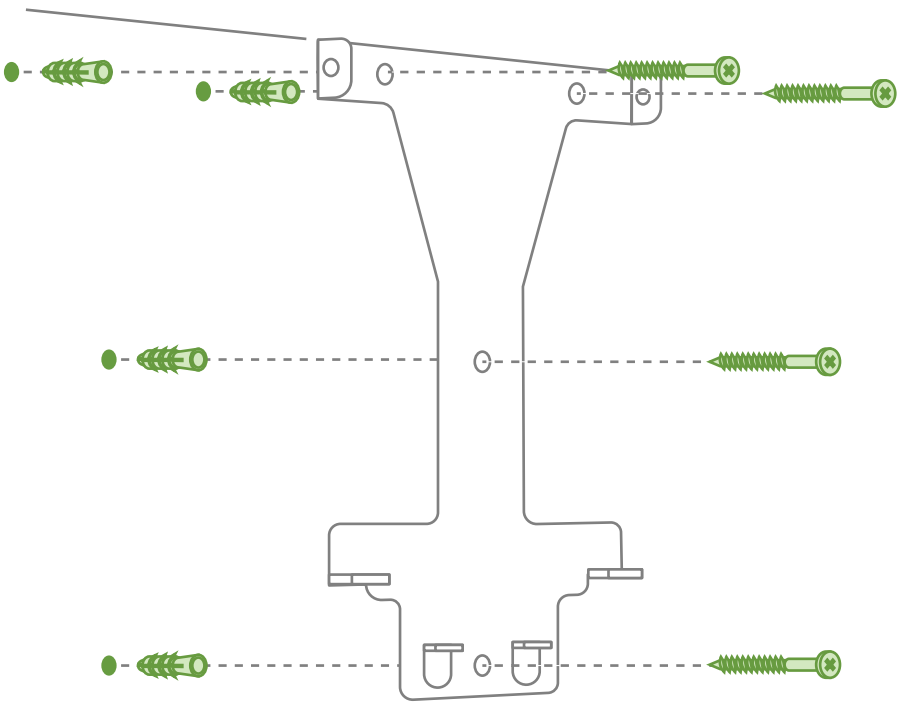

Need help?

- emporiaenergy.com/support
- support@emporiaenergy.com
- 1-844-EMPORIA (367-6742)

Step 5a: Install plastic cradle

First, use a bubble level to draw a horizontal line at least 12" away from the mounting bracket at the height you'd prefer. Next, holding the flat part on the top of the cradle up to the line, mark the 3 mounting holes of the cradle. Next, drill a 1/4" (6mm) hole in the wall for each mark. Then, use a hammer to tap in 3 drywall anchors. Finally, install the cradle with 3 Phillips screws into the anchors.

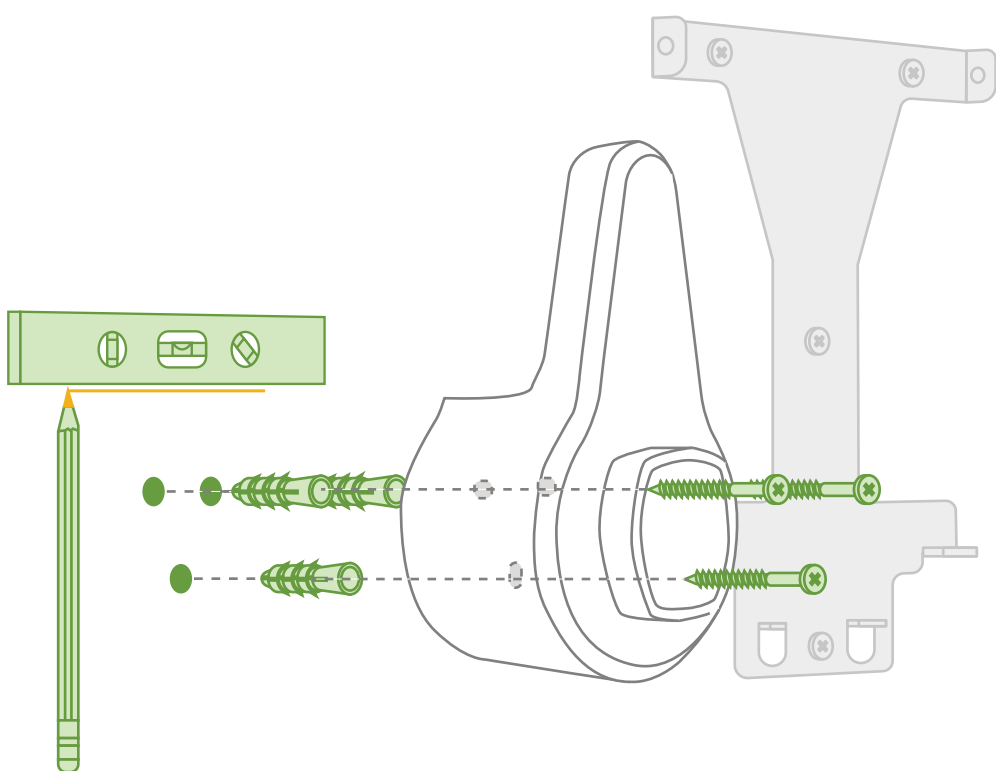

Need help?

- 🗨 emporiaenergy.com/support
- ✉ support@emporiaenergy.com
- ☎ 1-844-EMPORIA (367-6742)

Step 5b: Install metal cradle

First, use a bubble level to draw a horizontal line at least 12" away from the mounting bracket at the height you'd prefer. Next, holding the cradle up to the line, mark the 4 mounting holes of the cradle. Next, drill a 5/16 inch (8mm) in the wall for each mark. Then, use a hammer to tap in 4 drywall anchors. Finally, install the cradle with 4 Phillips screws into the anchors.

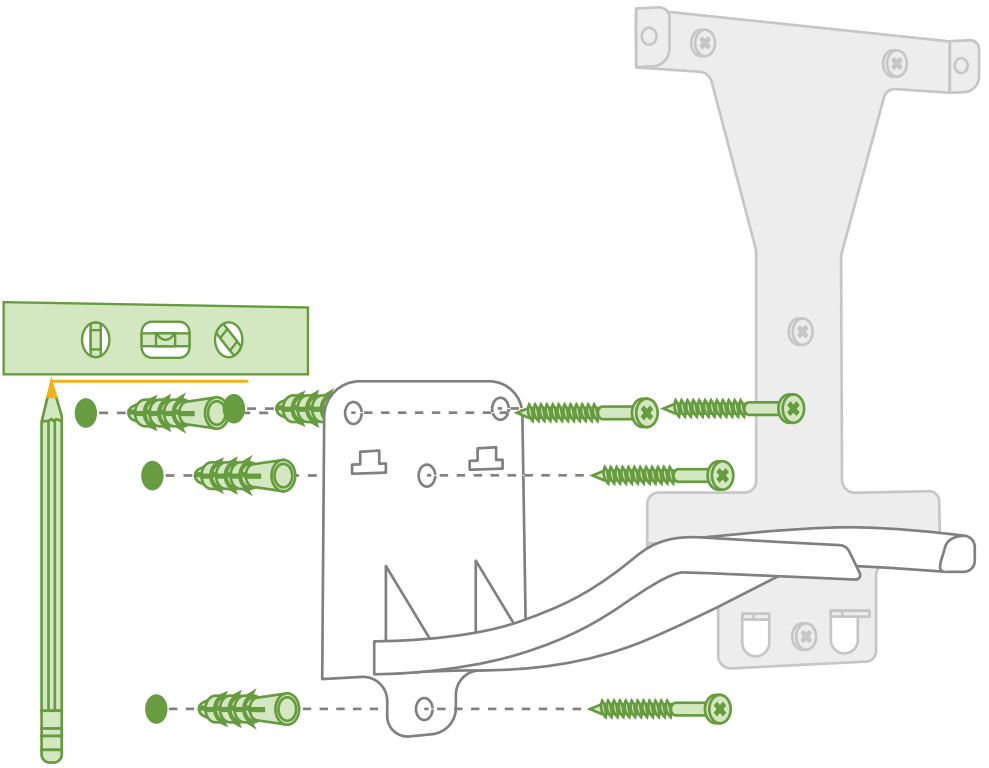

Step 6: Mount the charging station

Use a Phillips screwdriver and the 4 Phillips bolts to install the charging station on the mounting bracket.

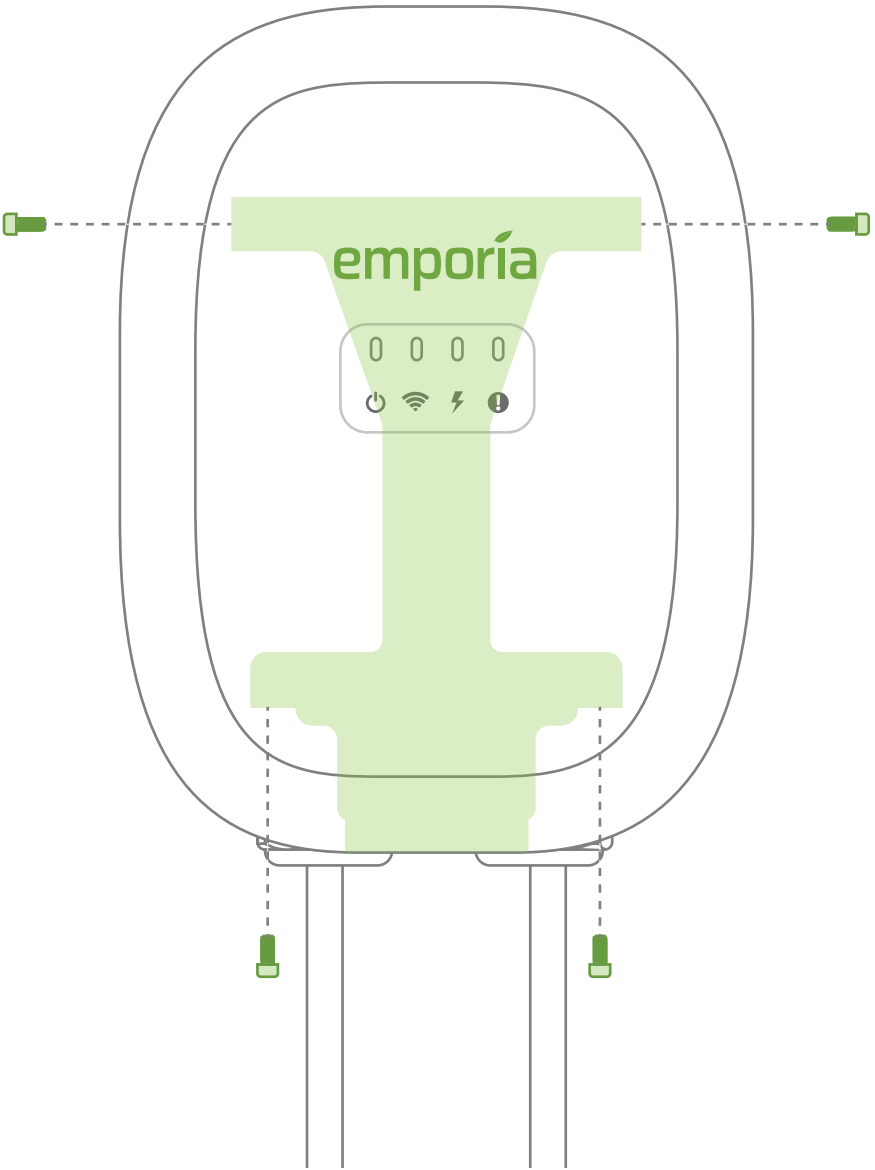

Need help?

-  emporiaenergy.com/support
-  support@emporiaenergy.com
-  1-844-EMPORIA (367-6742)

Step 7: Electrician instructions

The Emporia EV Charger comes pre-configured with 1 of 2 power input types.

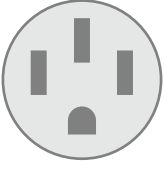

Plugged-in (NEMA 14-50 plug) See Step 7a

- EV Charger can supply a max charge of 40A
- Requires a dedicated, dual-pole breaker (50A recommended for full 40A Charge Rate) and a NEMA 14-50 receptacle outlet
- Can be converted to Hardwired. Visit emporiaenergy.com/installation-guides



Hardwired (whip conduit) See Step 7b

- EV Charger can supply a max charge of 48A
- Requires a dedicated, dual-pole breaker (60A recommended for full 48A Charge Rate).
CAUTION: To reduce the risk of fire, connect only to a circuit with 60A maximum branch circuit over current protection in accordance with the National Electrical Code, ANSI/NFPA 70, the Canadian Electrical Code, Part I, C22.1, and any local electrical codes.

Dedicated Breaker	Charge Power @ 240V	
15A	2.9kW	12A
20A	3.8kW	16A
25A	4.8kW	20A
30A	5.8kW	24A
35A	6.7kW	28A
40A	7.7kW	32A
45A	8.6kW	36A
50A	9.6kW	40A
60A	11.5kW	48A

Step 7a-1: Plugged-in instructions for electricians



If a NEMA 14-50 receptacle outlet is not already at the charging station location, a licensed electrician or other qualified professional can follow these instructions to install one. **First, turn off the dedicated dual-pole breaker that will power the EV Charger.** This breaker size needs to be set in the Emporia app and protected by a PIN in Step 8.

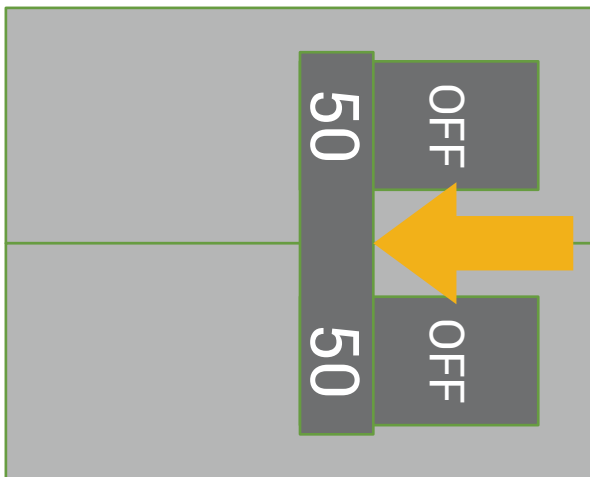

Need help?

- emporiaenergy.com/support
- support@emporiaenergy.com
- 1-844-EMPORIA (367-6742)

Step 7a-2: Plugged-in instructions for electricians



Install a NEMA 14-50 receptacle outlet with the ground facing downward ensuring the distance between the NEMA outlet and the charging station allows slack for a short cable. Bring leads from both phases of the breaker along with a ground/earth lead to the outlet and connect them. **Neutral is not required.**

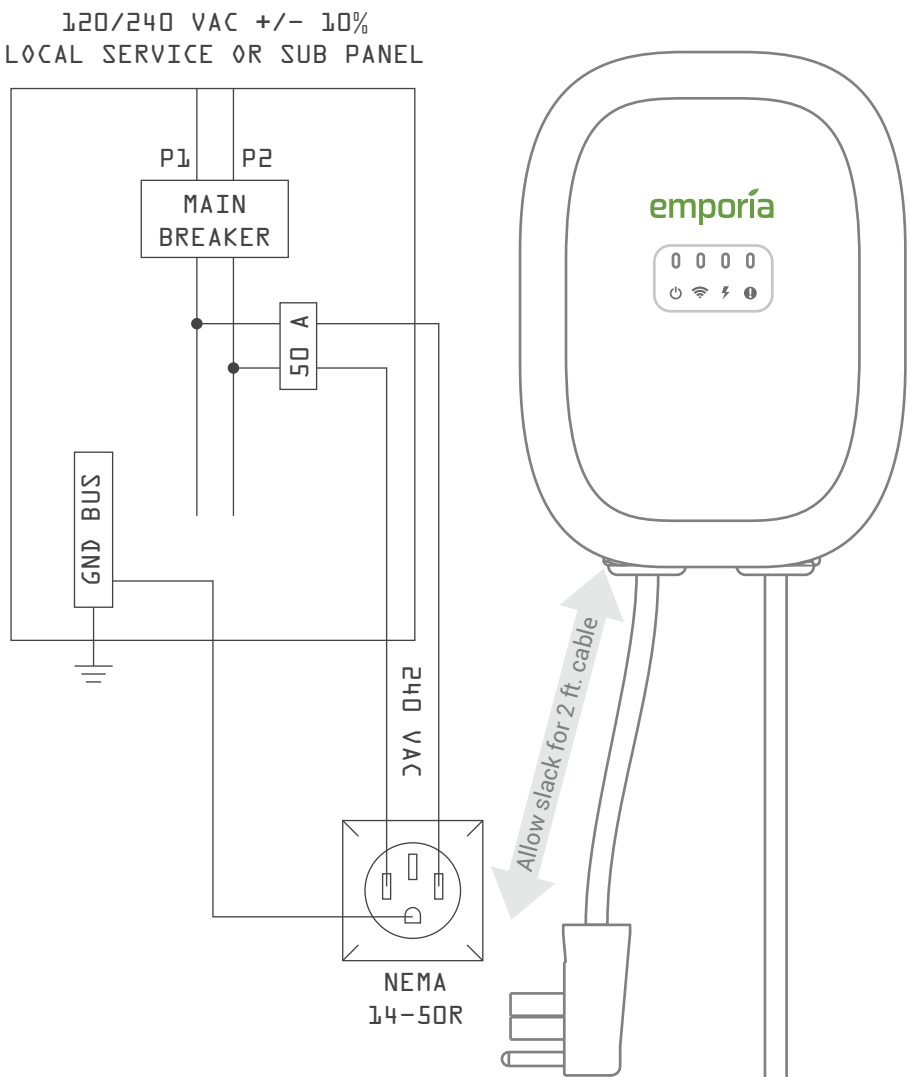

Step 7a-3: Plugged-in instructions for electricians

Plug in the NEMA 14-50 plug from the charging station into the receptacle outlet. Turn on the breaker and ensure that the power light on the front of the charging station is illuminated.

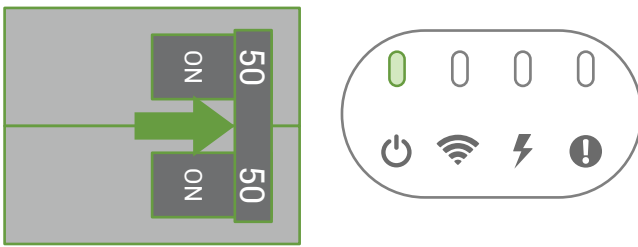

Step 7b-1: Hardwired instructions for electricians

A licensed electrician or other qualified professional can follow these instructions to hardwire the charging station to a breaker. **First, turn off the dedicated dual-pole breaker that will power the EV Charger.** This breaker size needs to be set in the Emporia app and protected by a PIN in Step 8.

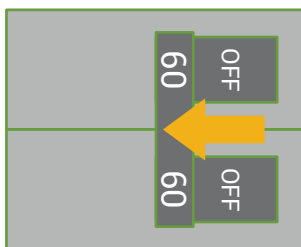

Need help?

- emporiaenergy.com/support
- support@emporiaenergy.com
- 1-844-EMPORIA (367-6742)

Step 7b-2: Hardwired instructions for electricians



Use 90°C wire, 6 AWG copper from both phases of the breaker along with a ground/earth lead coming from the charging station hardwire whip conduit. Bring leads from both phases of the breaker along with a ground/earth lead to a junction box and connect them to the **Line 1** (120V AC to Ground), **Line 2** (120V AC to Ground), and **Ground** from the Charger. Then, connect the ¾" NPT conduit fitting and sealing washer through a 1 ⅛" tap to the junction box for a watertight seal.

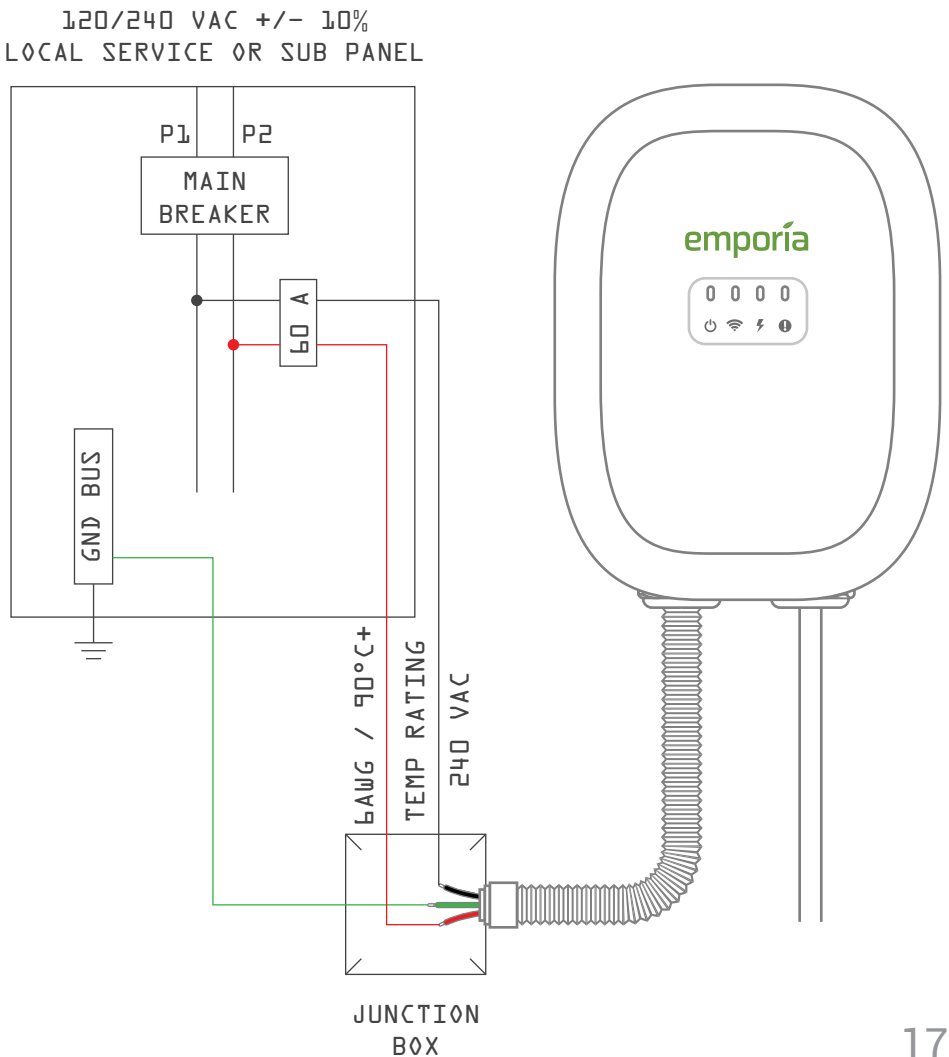

Step 7b-3: Hardwired instructions for electricians



Turn on the breaker and ensure that the power light on the front of the charging station is illuminated.

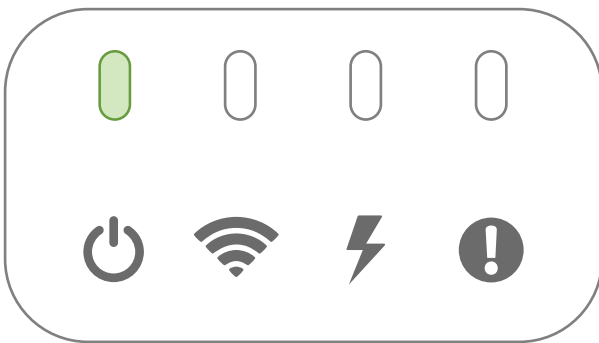
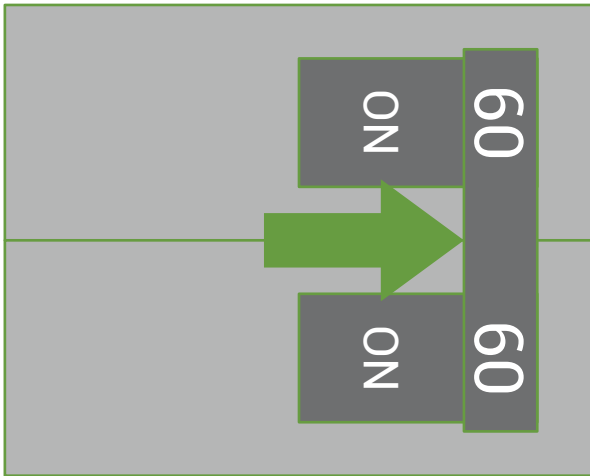

Need help?

- emporiaenergy.com/support
- support@emporiaenergy.com
- 1-844-EMPORIA (367-6742)

Step 8: Complete setup

Your Emporia EV Charger is now ready to charge your vehicle. It is set from the factory to charge at 40A (NEMA 14-50) or 48A (Hardwired). To raise or lower the charge rate to match your breaker size and installation type, as well as to take advantage of the numerous other features available from Emporia, return to the Emporia Energy app, choose Add a Device under Manage Devices and follow the instructions to set up your EV Charger. **A PIN must be set in the app when setting the breaker size.** Once your phone has connected to the EV Charger via Bluetooth, you'll be prompted to connect to a nearby Wi-Fi router. Make sure you have your Wi-Fi network name and password available.

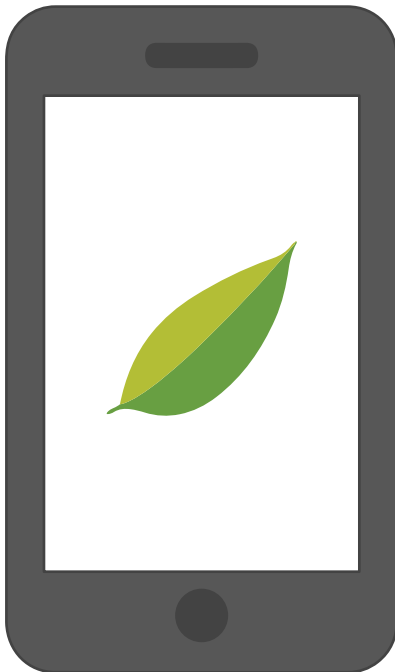

Need help?

- 🗨 emporiaenergy.com/support
- ✉ support@emporiaenergy.com
- ☎ 1-844-EMPORIA (367-6742)

Charging your vehicle



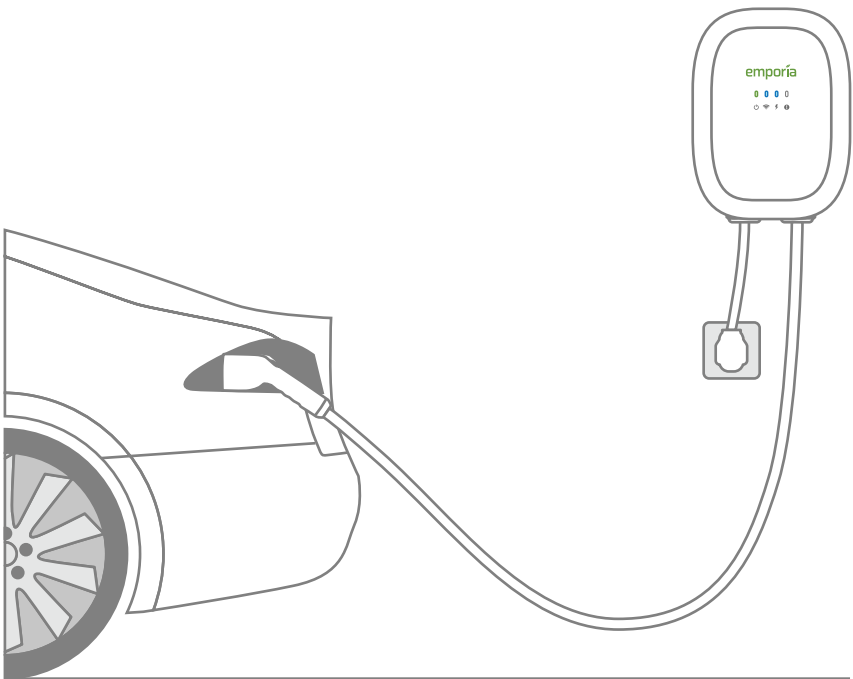

Each time the EV Charger is used, the cables, charging connector, and charging station should be inspected for damage. To charge your vehicle, open the vehicle port door and plug the connector into the port. You will see the charge light on the EV Charger switch to solid blue when it is connected to the vehicle. It will begin breathing blue as the vehicle charges. Additionally, most EVs have indicator lights on the dashboard to let you know that you're charging. Do not attempt to drive your vehicle while the charge cable is connected to your vehicle. Please contact Emporia Customer Support with any questions.



Need help?

- 🗨 emporiaenergy.com/support
- ✉ support@emporiaenergy.com
- ☎ 1-844-EMPORIA (367-6742)

EV Charger LED lights

 Power	
Off	Charger does not have power
Solid green	Charger has power
 Charge	
Off	No vehicle connected
Solid Blue	Vehicle connected
Flashing Blue	Offering charge
Breathing Blue	Vehicle charging
 WiFi	
Solid Red	Not connected to router
Flashing Red	Lost connection to router
Flashing Green	Connecting to router
Solid Green	Connected to router, but not the Internet
Solid Blue	Connected to the router and the Internet
 Fault	
Flashing orange 1 slow/ 1 fast	Abnormal control pilot circuit Unplug and plug-in Emporia EV Charger. If issue persists, contact Support.
Flashing orange 1 slow/ 2 fast	Charger has exceeded operating temperature lower bound. Ensure the charger is installed where temperatures do not drop below -22F (-30C)
Flashing orange 1 slow/ 3 fast	Input voltage is too low If plugged in, check that the NEMA 14-50P is plugged in securely. Check the supply breaker in your breaker panel for damage and replace if necessary. If issue persists, contact Support.
Flashing orange 1 slow/ 4 fast	Input voltage is too high If plugged in, check that the NEMA 14-50P is plugged in securely. Check the supply breaker in your breaker panel for damage and replace if necessary. If issue persists, contact Support.
Flashing orange 1 slow/ 5 fast	Charger has exceeded nominal temperature Ensure the charger is installed where ambient temperatures will not exceed 122°F (50°C). If issue persists, contact Support.

Need help?

-  emporiaenergy.com/support
-  support@emporiaenergy.com
-  1-844-EMPORIA (367-6742)

EV Charger LED lights (cont.)

! Fault (cont.)	
Flashing orange 1 slow/6 fast	Output surge current Unplug from car. Disconnect charger from power. Confirm there is no visible damage or foreign material in the EV connector. Return power to charger. If issue persists, contact Support.
Flashing orange 1 slow/7 fast	Current leakage Unplug from vehicle. Disconnect charger from power. Confirm there is no visible damage or foreign material in the EV connector. Return power to charger. If issue persists, contact Support.
Flashing orange 1 slow/8 fast	Output short circuit Unplug from vehicle. Disconnect charger from power. Confirm there is no visible damage or foreign material in the EV connector. Return power to charger. If issue persists, contact Support.
Flashing orange 1 slow/9 fast	Output over current Unplug from vehicle. Disconnect charger from power. Confirm there is no visible damage or foreign material in the EV connector. Return power to charger. If issue persists, contact Support.
Flashing orange 2 slow/3 fast	Relay fused in position Disconnect from power immediately. Contact Support.
Flashing orange 2 slow/5 fast	Charger is not grounded Ensure that the EV Charger is properly wired and grounded. For NEMA 14-50 installs, check the line and neutral connections in the outlet as they may be reversed. Unplug and reboot EV charger. If issue persists, contact Support.
Flashing orange 3 slow/1 fast	The vehicle is requesting ventilation during charging, which is not supported by the Emporia EV Charger. Contact Support.
Flashing orange 3 slow/2 fast	The vehicle is requesting charge but the charger is not ready. Unplug the connector from the port and plug it back in again. If issue persists, contact Support.

Need help?



-  emporiaenergy.com/support
-  support@emporiaenergy.com
-  1-844-EMPORIA (367-6742)

Troubleshooting Tips

The Emporia Energy app is not finding my EV Charger after I've installed it.

- Ensure the EV Charger has power:
 - Check for a green power light.
 - Check the EV Charger is wired properly.
 - Check that the breaker powering the EV Charger is turned on.
- Ensure your phone can connect to the EV Charger.
 - Check your phone's Bluetooth is on.
 - If you're using an Android, turn on Location Services for your phone to properly scan for Bluetooth devices.
- Try power cycling the breaker to which the EV Charger is connected.
- Try restarting the Emporia App.
- Try rebooting your phone.

My vehicle is not responding or charging.

- Ensure that the latch on the EV charging cable handle is locked into place. If the handle is not latched securely, the vehicle will not charge. If the latch is pressed down during charging, the charging automatically stops.
- Ensure that the vehicle is not set up to begin charging at a specific time of day, location, or some other setting that is preventing charging.
- Ensure the EV charger icon  is in a **blue** ready state on home page. If it is in a **green** paused state tap the icon  to un-pause charger.

Technical Specifications

Input Voltage	208/240VAC 50/60Hz
Power Charge	11.5kW (240V/48A) / 9.6kW (240V/40A) / 10kW (208V/48A) / 8.3kW (208V/40A)
Required Breaker	Dedicated 50A+ dual pole for 40A Dedicated 60A+ dual pole for 48A
Connector	24' cable SAE J1772 or NACS connector
Power Wiring	NEMA Type 14-50 (up to 40A) with < 6 ft long cable, compliant with 2023 NEC Section 625.17(A)(3)(a)(ii) / Hardwired (up to 48A)
Enclosure	Watertight NEMA Type 4 indoor/outdoor
Temp Range	-22°F to 122°F (-30°C to 50°C)



FCC ID: 2AS6P-EMEVSE1
Model: EMEVSE1



IC: 28084-EMEVSE1
CAN ICES-003(B) / NMB-003(B)

The Emporia Smart Home EV Charger contains FCC ID: 2AS6P-EMEVSE1. This device complies with part 15 of the FCC Rules. Operation is subject to the following two conditions: (1) this device may not cause harmful interference, and (2) this device must accept any interference received, including interference that may cause undesired operation. This equipment complies with FCC RF radiation exposure limits set forth for an uncontrolled environment. This equipment should be installed and operated with a minimum distance of 20 centimeters between the radiator and your body.

Caution: Any changes or modifications not expressly approved by Emporia void the user's authority to operate the equipment.